



**Tecma
Drive,S.L.**
PROFESSIONAL FOR ROTATION

SLEWING RING CATALOGUE



Tecma Drive S.L.
info@tecmadrive.com
www.tecmadrive.com

Index

Brief introduction	p. 4
Product feature	p. 5
Application examples	p. 6
Transport, storage and mounting preparation	p. 7
Safety coefficient	p. 8
Calculation of singlerow four-points contact ball slewing ring	p. 9
Flatness	p. 10
Pre-load forces and tightening torques for metric bolts	p. 11
Structure's flange	p. 12
Reference identification	p. 13
Lubrication	p. 14
Assembly	p. 15
Slewing rings - Without teeth (SD)	p. 16
Slewing rings - With external teeth (E)	p. 22
Slewing rings - With internal teeth (I)	p. 32
Slewing rings - Special models	p. 42

Brief introduction

TECMA DRIVE is a brand that positions itself in the industrial and solar market with the versatility and quality that a product needs to satisfy the demands of the ample and overparticular sector.

Behind TECMA DRIVE there is a long trajectory in the sector with an experience over 15 years, which allows us to commercialize and guarantee a product that meets the needs of the market.

In order to battle the wide demand of different sectors, TECMA DRIVE provides technical support and calculation solutions.

All factories used for the manufacture of our products currently possess all required ISO certification and have been audited by TECMA DRIVE staff. These factories are obliged to adhere to the TECMA DRIVE standards and quality specifications which cover all aspects of design, materials, and manufacture.

WARRANTY

TECMA DRIVE slewing rings are guaranteed for 12 months (with the possibility to extend it) after delivery to be free from material defect and manufacturing or assembly error.

TECMA DRIVE assumes no liability for damages arising from:

- Improper selection of product by the customer
- Failure to follow the instructions and information in this manual
- Improper use of the product
- The use of untrained personnel
- Any modifications to the product as delivered



Product features

TECMA DRIVE's light and reinforced series of slewing rings comply with international standards, requirements and are approved for different simple and complex applications

Slewing rings are composed of two rings, one inner and one outer, in which raceway are obtained that contain rolling elements on which the working loads are transmitted from the moving ring to the fixed one. They should be transported and stored horizontally or on specially adapted incline frames.

The raceways of our slewing ring are hardened, and the soft area is properly marked. The slewing rings can be supplied without gear, internal or external toothed. The suffixes corresponding to each version are E. (external teeth), I. (internal teeth) and SD. (without teeth). TECMA DRIVE can also provide also slewing rings with clearance limitations and centering coefficients. Slewing's rings with anti-corrosion or painted treatment are also available upon request. The materials used for the slewing rings are the following: C45 N, C45 B, 42 CrM04 N, 42 CrM04 B.

The teeth of our standard slewing rings are not hardened. However, at the request of our clients, these types of treatments can be performed following special requests or requirements. The operating temperature of our slewing rings ranges from -25°C to + 60°C. All our slewing rings include a protective seal on each inner ring; the seal is made of NBR material that is characterized by a good resistance to oil and grease and guarantees a perfect sealing protection.

If conditions require a different seal, TECMA DRIVE can provide alternative solutions according to your application. TECMA DRIVE slewing rings are sold with pre-lubricated raceways and come rust protected.

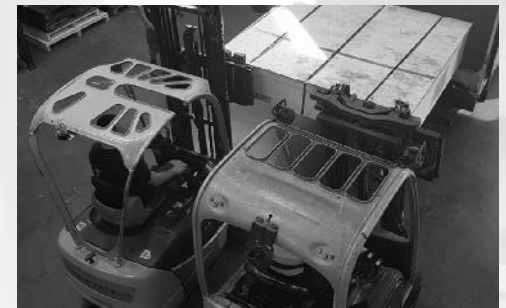

Application Examples



1. Tower Cranes



2. Mining Equipment



3. Hand Lifting Manipulators



4. Elevator Machines



5. Maritime Cranes



6. Packaging Machines



7. Bottling Machines



8. Renewable Energy Sources

Transport, Storage and Mounting Preparation

TECMA DRIVE's light and reinforced series of the slewing rings comply with international standards, requirements and are approved for different simple and complex applications. Vibrations during transport should be minimized because they may damage the raceways. Shock loads should be avoided to prevent damage to the raceways. Caution must be taken not to dislodge seals or grease nipples during movement. Wooden or rubber spacers should be used to separate unwrapped rings stacked vertically to avoid surface damage. Gear teeth should be protected from impact damage.

Light surface corrosion may occur in humid conditions, but it can be easily removed from the external surface. It is very important that the raceways are well greased to remain rust free. For this reason, slewing rings are pre-lubricated with grease.

In case of long storage time, the slewing rings may need professional cleaning and greasing before use. For this reason, those that are sold after long time storage are inspected before being sent.

If the slewing ring has threaded holes, eyebolts can be used for manipulation or lifting. For safety reasons, check the weight of the ring to ensure any slings or chains used are suitable. Slewing rings must not be suspended from a crane by a single sling or placed on the ground vertically as they may deform under their own weight.

Degrease and clean the slewing rings, especially the mounting faces. Use degreaser sparingly and do not let the fluid work its way under the seals and into the raceway. The datum plane of slewing rings and the installing platform should be cleaned up lest the sundries and welding slag should affect the installing precision. The installing support should be rigid enough to prevent the slewing rings from distorting and affecting the performance.



Storage



Packaging



Transportation



Technical info



Sales

Safety Coefficient

Forces to consider in slewing rings:

- Total axial force F_a (10^4N)
- Total overturning moment M_r (10^4 Nm.)
- Total radial force F_r of the fractional surface of overturning moment (10^4 N)
- Gear forces F_n

When the type selection is calculated, the static condition of the slewing ring, F_a , M_r , F_r and Dynamic conditions of forces F_a , M_r , F_r should be calculated separately. If host ascends, ascension load should be multiplied by the inertia coefficient K , $K= 1,25$.

Table-Slewing ring safety coefficient								
Application of the slewing ring			The type of slewing ring					
			Q,01		02		J.11:S.13	
			fs	fd	fs	fd	fs	fd
Tower crane for construction	Upper type of slewing	$M_f \leq 0.5M$	1.25	1.36	1.25	1.25	1.00	
		$0.5M < M_f < 0.8M$		1.55			1.15	
		$M_f \geq 0.8M$		1.71			1.26	
		Under type of slewing rings		1.36		1.00	1.07	
Wheel crane, stacker-reclaimer and all kinds of the workbench			1.10		1.10	1.10	1.10	1.00
Cantilever crane, port crane, all kinds of loading and unloading machinery			1.25	1.55	1.25	1.15	1.25	1.13
Belt conveyor handling with tower cranes and crawler cranes				1.71	1.10	1.26		1.23
Grab and shovel excavator, dredger, floating crane			1.45	2.50	1.45	1.71	1.45	1.62
Excavators of bucket capacity $<1.6\text{m}^3$					1.25	1.26		1.45
Excavators of bucket capacity $\geq 1.6\text{m}^3$			1.75	3.00	1.45	1.75	1.45	
Metallurgical crane, bucket wheel excavators, tunnel boring machine			2.00	3.50				

Table 1: Recommended safety coefficient slewing rings use

Calculation of single row four-point contact ball slewing ring

45° and 60°

Static working condition to selection

$\alpha = 45^\circ$

$$Fa' = (1,225Fa + 2,676Fr)fs$$

$$M' = 1,225Mfs$$

$\alpha = 60^\circ$

$$Fa' = (Fa + 5,046Fr)fs$$

$$M' = Mfs$$

Dynamic working condition to life checking

$\alpha = 45^\circ$

$$Fa' = (1,225Fa + 2,676Fr)fd$$

$$M' = 1,225Mfs$$

$\alpha = 60^\circ$

$$Fa' = (Fa + 5,046Fr)fd$$

$$M' = Mfd$$

Calculation of model single cross roller type

Static working condition to selection

$$Fa' = (Fa + 2,05Fr)fs$$

$$M' = Mfs$$

Dynamic working condition to life checking

$$Fa' = (Fa + 2,05Fr)fd$$

$$M' = Mfd$$

Fa: Nominal axial load (kN)
 Mr: Nominal tilting moment (kN.m)
 Fr: Nominal radial load (kN)
 Fa': Equivalent axial load (kN)
 M': Working tilting moment (kN.m)
 fs: Safety factor coefficient
 fd: Working axial load (kN)

Static Load Capacity:
 Axial load → (Coa)
 Radial Load → (Cor)
 Tilting Moment → (Mr)
 Dynamic Load Capacity:
 Axial Load → (CA)
 Radial Load → (CR)

Flatness

The flatness of the slewing rings mounting surface is critical to optimal performance. Oftentimes, mounting structures are welded or worked in a way which induces stresses into the structure. These stresses must be relieved, following which the slewing rings mounting surface must be machined flat. The amount of out-of-flatness allowable in the circumferential direction for four-point ball rings is shown in the table below.

Raceway diameter (mm)	Permissible flatness deviation of the mounting surface (mm)		
	Single row ball	Double row ball	Roller
>500	0.10	0.15	0.07
>1000	0.15	0.20	0.10
>1500	0.19	0.25	0.12
>2000	0.22	0.30	0.15
>2500	0.25	0.35	0.17
>4000	0.30	0.40	0.20
>6000	0.40	0.50	0.30

Table 2: Surface flatness requirements



Pre-load Forces and Tightening Torques for Metric Bolts

The safe operation and service life of the slewing rings are significantly influenced by the bolted connection. Therefore, it is necessary that the prescribed number, quality and dimensions of the bolts is observed. The supporting surface of the tapped part of the bolt and nut must not show any chambered corners. If a chambered angle is present, an additional alternating bending load is present, negatively affecting the service life of the bolt. In addition, the fixing holes of the rings and the connection construction must match, otherwise this will cause tension in the ring. When using bolts with a higher quality class than 8.8, refined washers according to DIN 6916 are prescribed under the bolt head and nut. Due to the high tightening force of the bolts, this otherwise leads to the flow of the material and thus to the reduction of the bolt tension and the loosening of the bolts. The washers can only be dispensed with for the slewing ring with refined rings.

Bolt Specification	Holes Diameter (mm)	Bolt Intensity Grade (GB3098.1-82)		
		8.8	10.9	12.9
		Intensity Limit of Bolt Material δ s/min (N/mm ²)		
		640	900	1080
Pre-tightening Moment of Torque MA (N·m)				
M10	11	44	62	75
M12	13.5	79	110	130
M14	15.5	120	170	210
M16	18	190	265	320
M18	20	260	365	435
M20	22	370	520	620
M22	24	500	700	840
M24	26	640	900	1080
M27	30	950	1350	1620
M30	33	1300	1800	2160

Table 3: Recommended bolt torque (UNC thread)

Structure's Flange

Although slewing rings are designed to support large axial, radial and moment loads they are inherently elastic structures that must be supported by flat, machined companion surfaces which are rigid enough to eliminate torsional buckling under load that would affect the smooth operation of the ring.

Thick circular supports are preferred over thinner supports with reinforcement ribs. Where there are high radial forces the ring should be properly supported on the reference diameters to ensure the bolts are not overloaded in shear.

The suggested thickness of the supporting rings are shown in the table below.

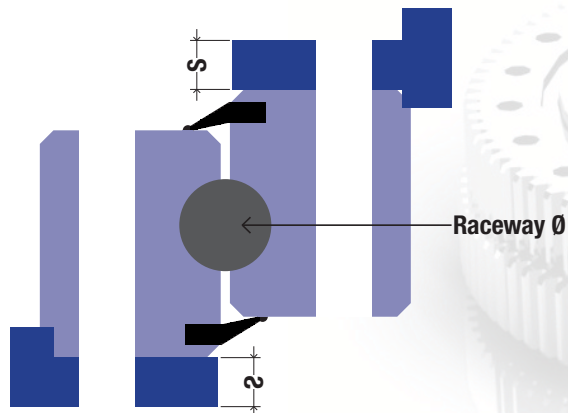
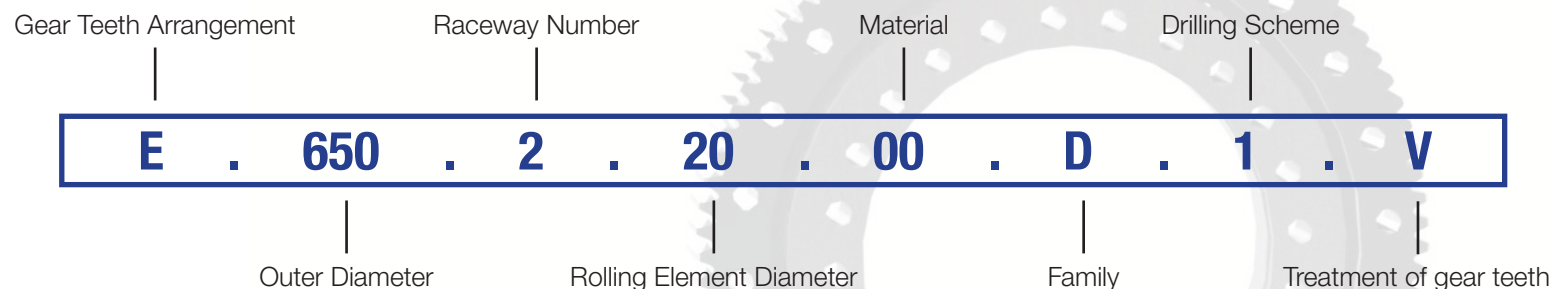

Figure 1: Support needed in slewing rings

Raceway diameter (mm)	Minimum support thickness (mm)
>500	25
>750	30
>1000	35
>1250	40
>1500	50
>2000	60
>2500	70
>3000	80

Table 4: Recommended minimum support thickness to reinforce ribs

Reference identification



Gear Teeth Arrangement:

SD = Without gear teeth
E = External gear teeth
I = Internal gear teeth

Outer Diameter:

Shown in mm. Ranges from 200mm to 3500mm.

Raceway Number:

Shown when it's a double row slewing ring (2).

Rolling Elements:

Shown in mm.

Material:

00 = C45 N
10 = C45 N and 42CrMo4
15 = 42CrMo4

Family:

A = Slewing ring with same diameter fixing holes in both inner and outer ring
B = Standard version
C = Light standard version
D = Special version

Drilling Scheme:

Slewing rings have through holes or threaded holes for fixing screws.

Treatment of gear teeth:

V = gear hardened flank teeth
W = gear hardened flank and bottom teeth

Lubrication

TECMA DRIVE slewing rings are pre-lubricated with a lithium-complex grease based on mineral oil with EP-additive. The recommended lubricants for the raceways are lithium plastic lubricants with the consistency level of 2 with EP additives.

Relubrication interval and lubricant quantity depends on operating conditions, which includes but is not limited to: load, rotational speed, operational environment properties, etc. For low-speed applications (mobile cranes, construction cranes, etc.), the relubrication interval is around 200 operating hours. For other applications, such as machines with higher rotational speed, equipment operating under permanent rotational speed or equipment in tropical conditions (excavators, universal finishing machines, magnetic separators, etc.), the re-lubrication interval is shorter, at approximately 70-100 operating hours.

If possible, relubrication should be done using the same grease as present on the slewing rings. When using different types of grease, it must be compatible with the current grease and with seal materials. Greases with different thickeners or base oils are generally not mixable. When in doubt, please contact the grease manufacturer.

The following table contains common greases for the slewing rings raceways and gears:

Company	Raceway	Gear
BP	Energrease LS - EP2	Energrease LC 2
Mobilux	Mobilux EP2	Mobilgear OGL 461
SHELL	Alvania EPLF2	Malleus OGH
MOTUL /BECHEM	Rhus L 474/2	Berulit GA 400
ESSO	BEACON EP 2	Multi-Purpose Grease (Moly)
TOTAL FINA	Multis EP2 - Lical	Ceran AD
ELF	Epexa 2 / Epexelf 2	Cardrexa DC1
CASTROL	Spheerol EPL 2	Castol LMX
ARAL	Aralub HLP2	Aralub MKA-Z 1

Table 5: TECMA DRIVE recommended raceway lubricants

Assembly

The ring must be mounted on a machined supporting structure, which must be clean, flat and rigid.

The mounting surface must be:

1. Free of any foreign matter (such as paint or welding beads).
2. Checked for their flatness and perpendicular deviations.

This helps to distribute proportionally the force on the ring, avoiding a concentration into restricted parts which would be harmful to the good working of the ring.

Shape defects of the supporting structure lead to deformation of the raceway; this can cause tight spots or possible seizure and will reduce the ring service.

The maximum flatness error depends on the constructive form of the ring and the medium diameter of the raceway (U.C.). This error must not exceed the limits reported in the table below. If this errors exceed of the recommended values, please contact our technical department.

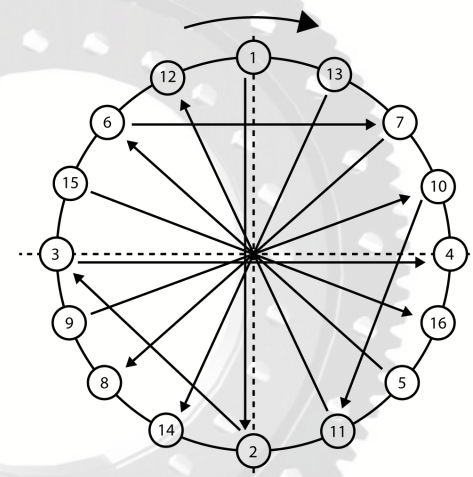

Figure 2: Order how to fix the slewing rings

Bolt clamp length $LK=5d$ (Bolt Diameter)

The nut intensity grade, allowed to be lower one grade than of the bolt, comply with the stipulation in the GB398.2-82 standard.

After installation:

1. Inspect whether the gear intervenes
2. Confirm whether the bolts have been completely
3. Confirm whether the operation is well

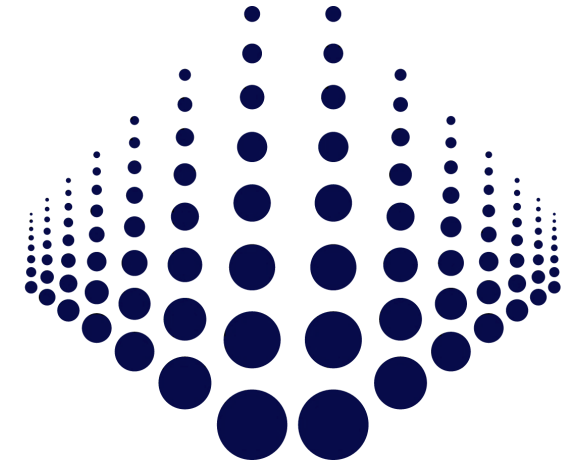

MODEL WITHOUT GEAR

SD 20.00.C

Light version, ball Ø20mm, ungeared, standard holes

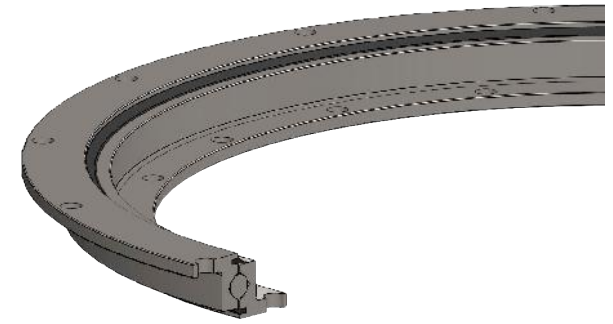
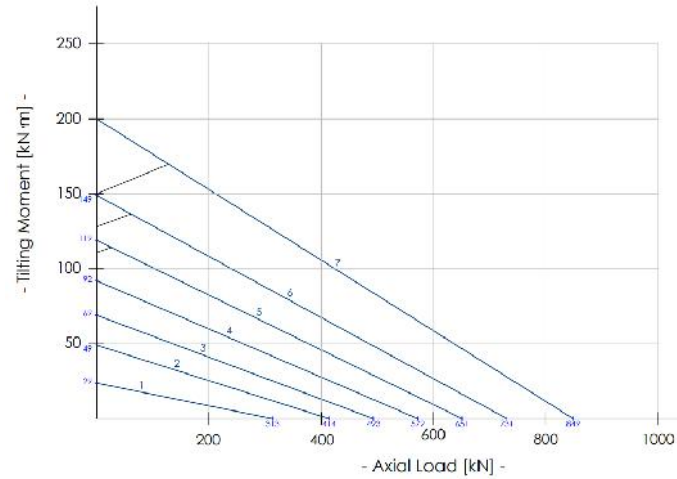
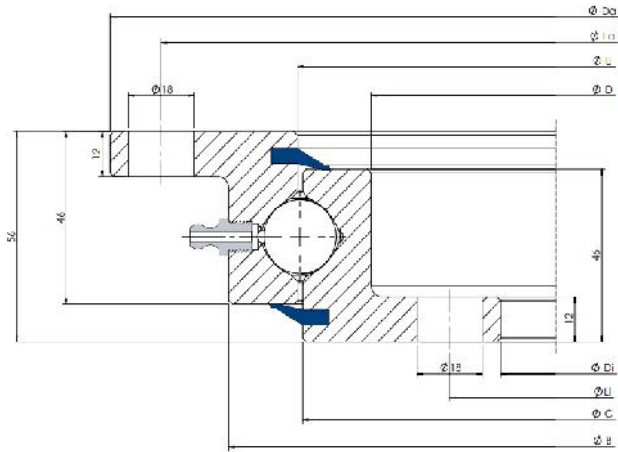

Slewing Ring Type	Dimensions						Fixing holes				Static		Dynamic		Mass
	Da mm	B mm	U mm	C mm	D mm	Di mm	La mm	na n°	Li mm	ni n°	Coa (kN)	Mr (kN·m)	Ca (kN)	Cr (kN)	Weight kg
1 SD.505.20.00.C	518	453	415.5	412.5	375	304	490	8	332	12	313	29	197	128	23.5
2 SD.650.20.00.C	648	583	545.5	542.5	505	434	620	10	462	14	414	49	218	142	31
3 SD.750.20.00.C	748	683	645.5	642.5	605	534	720	12	562	16	493	69	233	151	36.5
4 SD.850.20.00.C	848	783	745.5	742.5	705	634	820	12	662	16	572	92	246	160	43
5 SD.950.20.00.C	948	883	845.5	842.5	805	734	920	14	762	18	651	119	258	167	48
6 SD.1050.20.00.C	1048	983	945.5	942.5	905	834	1020	16	862	20	731	149	269	174	53
7 SD.1200.20.00.C	1198	1133	1095.5	1092.5	1055	984	1170	16	1012	20	849	200	284	184	62

SD 20.00.B

Standard version, ball Ø20mm, ungeared, standard holes

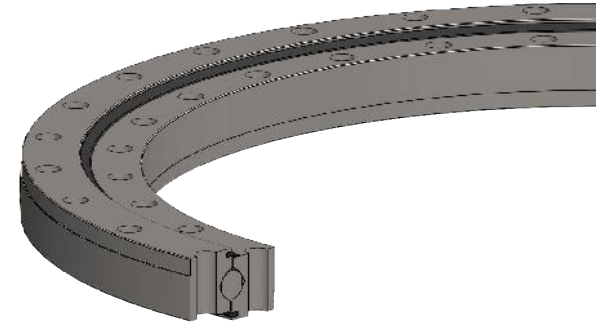
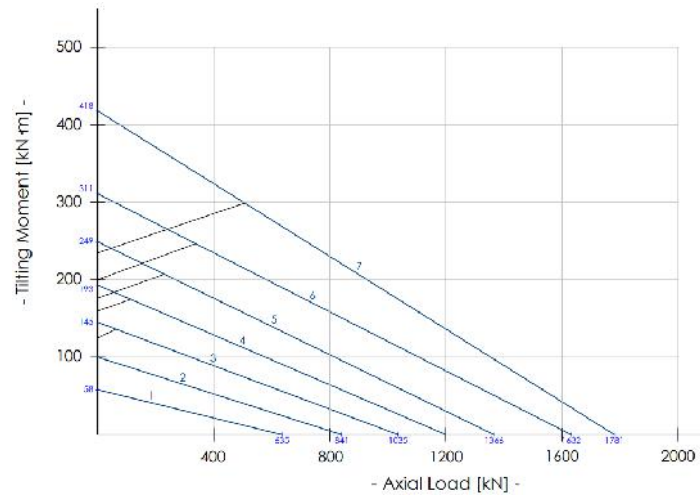
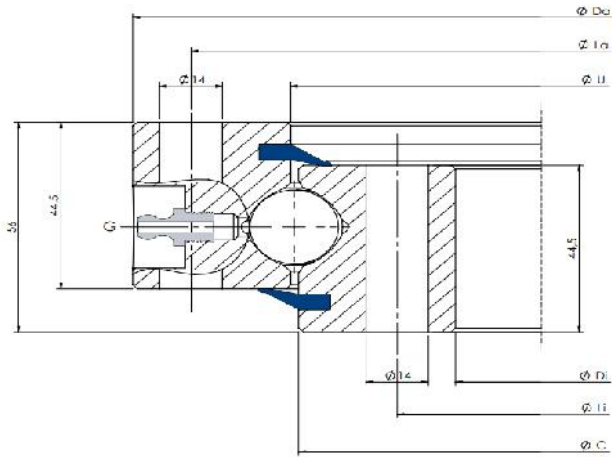

Slewing Ring Type	Dimensions				Fixing holes				Static		Dynamic		Mass
	Da mm	U mm	C mm	Di mm	La mm	na n°	Li mm	ni n°	Coa (kN)	Mr (kN-m)	Ca (kN)	Cr (kN)	Weight kg
1 SD.486.20.00.B	486	415.5	412.5	342	460	24	368	24	635	58	197	128	29
2 SD.616.20.00.B	616	545.5	542.5	472	590	32	498	32	841	100	219	142	37
3 SD.716.20.00.B	716	645.5	642.5	572	690	36	598	36	1035	145	233	151	44
4 SD.816.20.00.B	816	745.5	742.5	672	790	40	698	40	1201	193	246	160	52
5 SD.916.20.00.B	916	845.5	842.5	772	890	40	798	40	1366	249	258	167	60
6 SD.1016.20.00.B	1016	945.5	942.5	872	990	44	898	44	1632	311	269	174	67
7 SD.1166.20.00.B	1166	1096	1092.5	1022	1140	48	1048	48	1781	418	284	184	77

SD 25.00.B

Standard version, ball Ø25mm, ungeared, standard holes

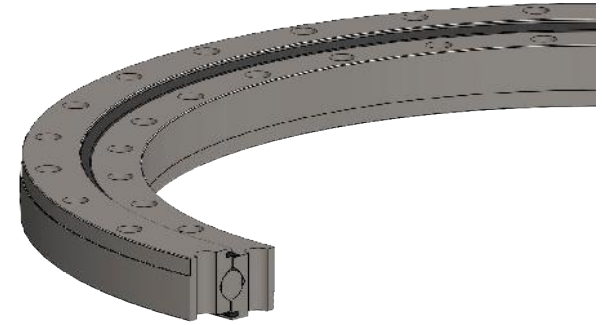
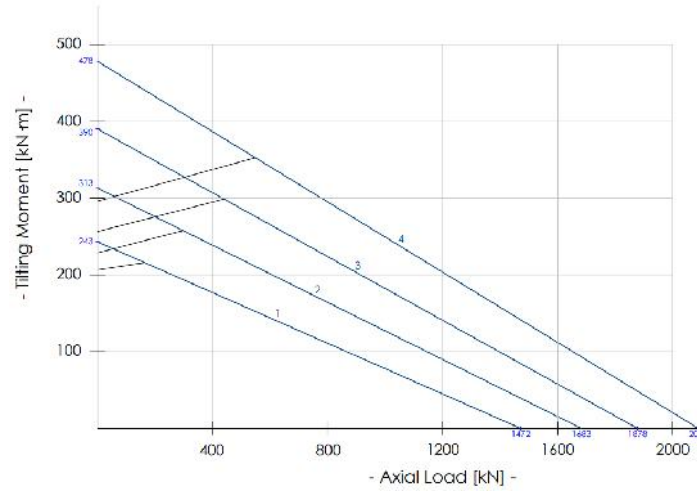
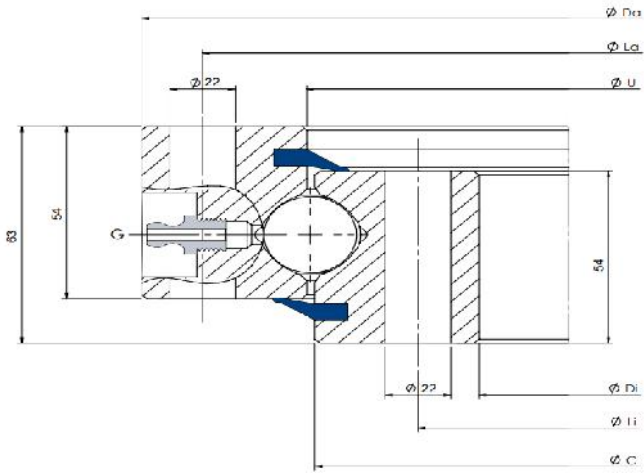

Slewing Ring Type	Dimensions					Fixing holes				Static		Dynamic		Mass
	Da mm	U mm	C mm	Di mm	La mm	na n°	Li mm	ni n°	Coa (kN)	Mr (kN·m)	Ca (kN)	Cr (kN)	Weight kg	
1 SD.855.25.00.B	853	756	756	657	815	24	695	24	1472	243	344	223	90	
2 SD.955.25.00.B	953	856	856	757	915	28	795	28	1683	313	362	235	101	
3 SD.1055.25.00.B	1053	956	956	857	1015	30	895	30	1878	390	376	244	115	
4 SD.1155.25.00.B	1153	1056	1056	957	1115	30	995	30	2090	478	391	254	128	

SD XX.00.D

Special version, different ball \varnothing in mm, ungeared, special holes

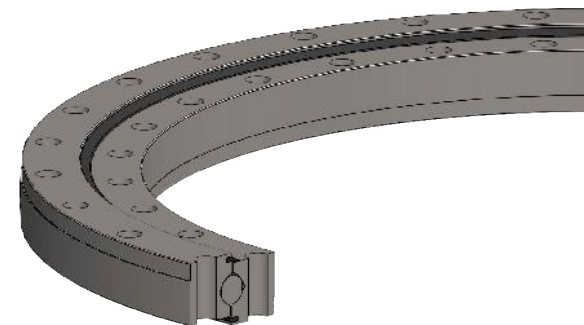
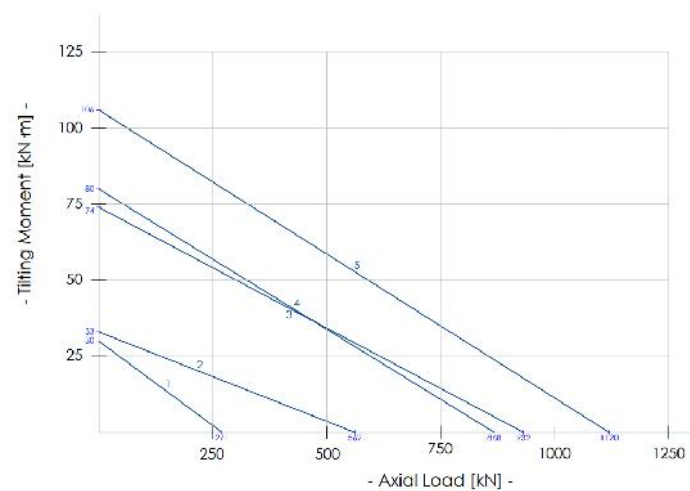
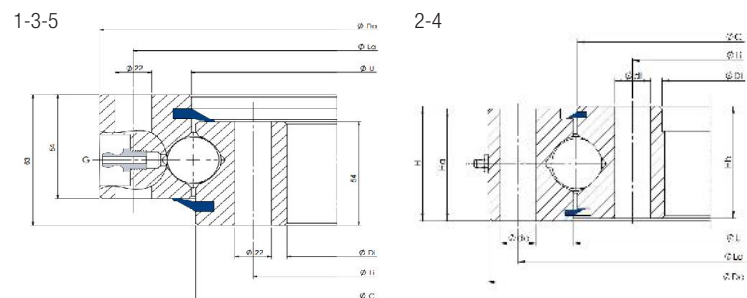

Slewing Ring Type	Dimensions							Fixing holes						Mass
	Da mm	U mm	C mm	Di mm	Ha mm	Hb mm	H mm	La mm	na n°	da mm	Li mm	ni n°	di mm	Weight kg
1 SD.234.14.00.D.1	234	180.5	177.5	124.5	30	30	35	214	24-1	11	144.5	20	11	7
2 SD.329.20.00.D.1	327	262	258	192	44	44	45	305	16	14	215	16-1	14	18
3 SD.430.25.15.D.1	430	348	342	260	53	53	65	400	24	14	290	20	16	32
4 SD.475.20.00.D.1	474	404	403	336	44	44	45	450	24	14	360	24	14	30
5 SD.505.25.15.D.1	505	416.5	413.5	325	64.5	60	66	475	24	17	355	24	17	48

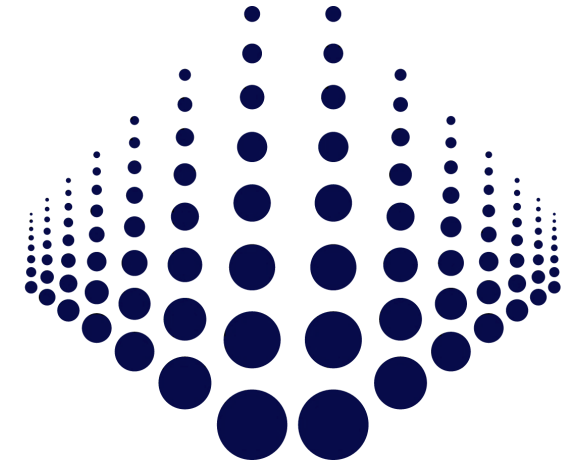
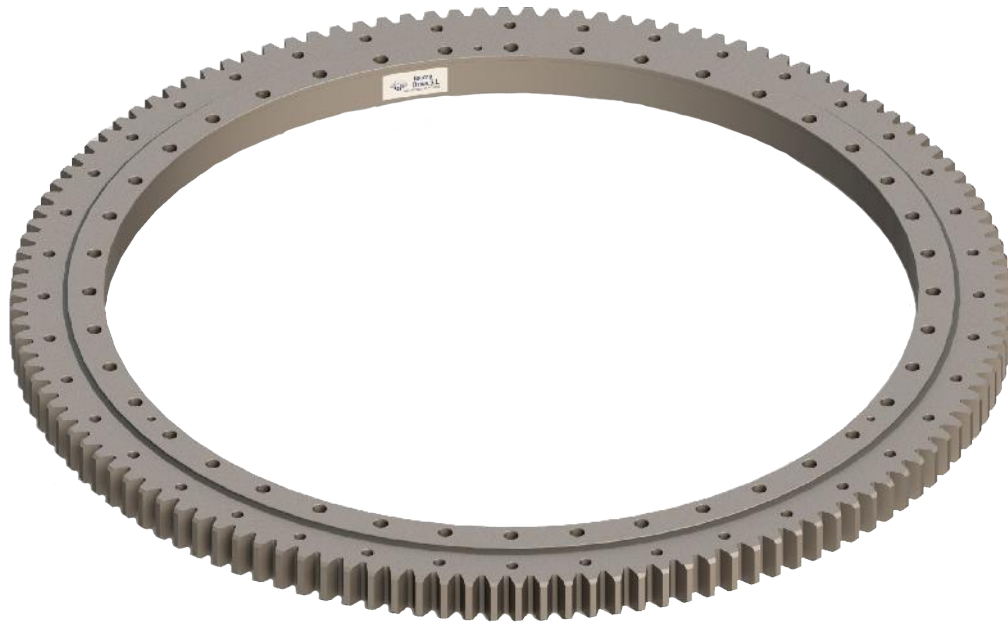

MODEL EXTERNAL GEAR

E 20.00.C

Light version, ball Ø20mm, external geared, standard holes

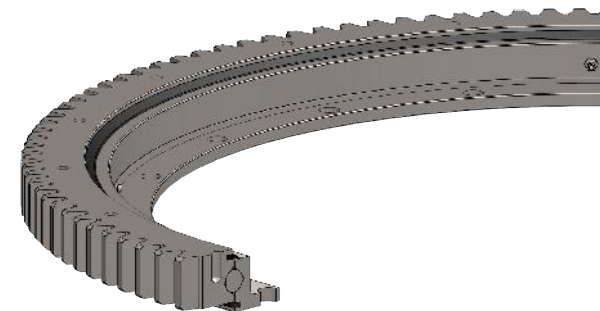
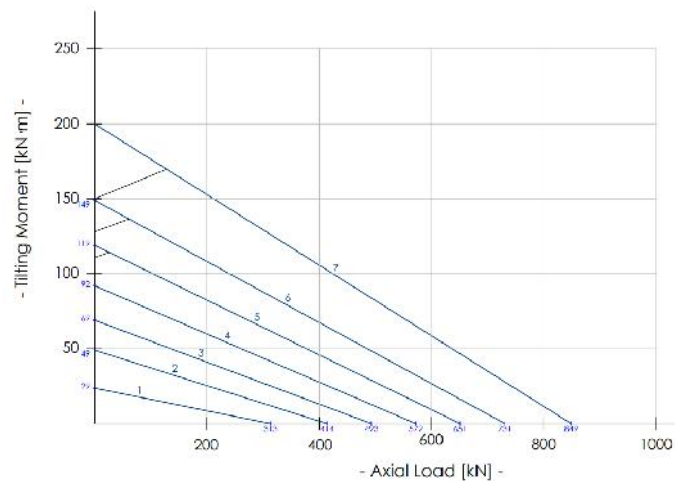
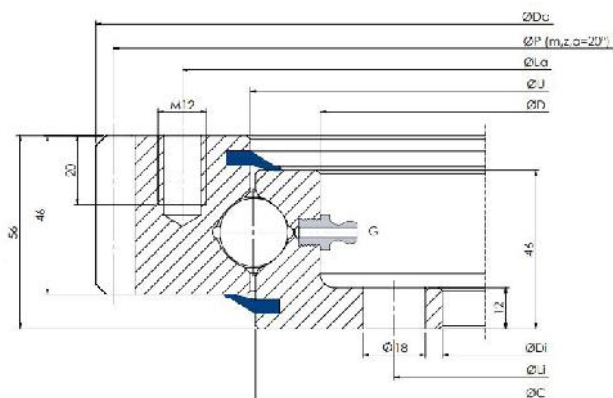

Slewing Ring Type	Dimensions					Fixing holes				Gear			Tooth Force		Static		Dynamic		Mass
	Da mm	U mm	C mm	D mm	Di mm	La mm	na n°	Li mm	ni n°	P mm	m	z n°	Fz nor. kN	Fz max. kN	Coa (kN)	Mr (kN-m)	Ca (kN)	Cr (kN)	Weight kg
1 E.505.20.00.C	504	415.5	412.5	375	304	455	10	332	12	495	5	99	17.8	24.9	313	29	197	128	29
2 E.650.20.00.C	640.8	545.5	542.5	505	434	585	14	462	14	630	6	105	21.2	29.7	414	49	218	142	40
3 E.750.20.00.C	742.8	645.5	642.5	605	534	685	16	562	16	732	6	122	21.2	29.7	493	69	233	151	47
4 E.850.20.00.C	838.8	745.5	742.5	705	634	785	18	662	16	828	6	138	21.2	29.7	572	92	246	160	53
5 E.950.20.00.C	950.4	845.5	842.5	805	734	885	18	762	18	936	8	117	28.3	39.6	651	119	258	167	64
6 E.1050.20.00.C	1046.4	945.5	942.5	905	834	985	20	862	20	1032	8	129	28.3	39.6	731	149	269	174	69
7 E.1200.20.00.C	1198.4	1095.5	1092.5	1055	984	1135	22	1012	20	1184	8	148	28.3	39.6	849	200	284	184	82

E 32.00.C

Light version, ball Ø32mm, external geared, standard holes

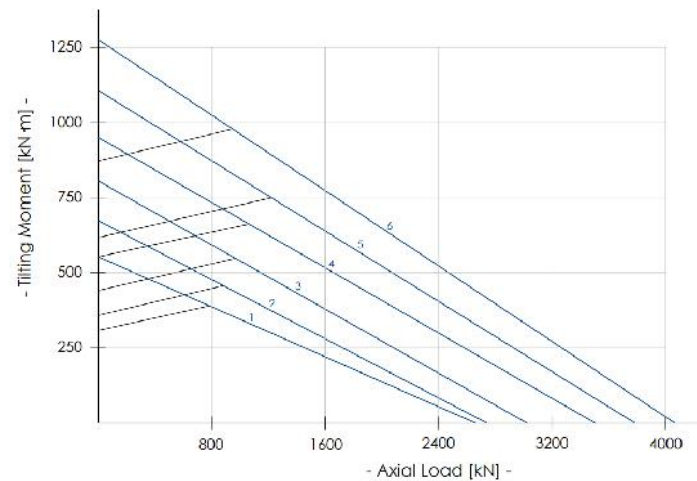
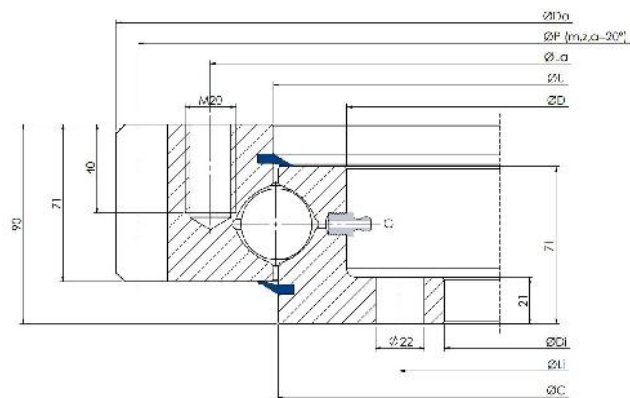

Slewing Ring Type	Dimensions					Fixing holes				Gear			Tooth Force		Static		Dynamic		Mass
	Da mm	U mm	C mm	D mm	Di mm	La mm	na n°	Li mm	ni n°	P mm	m	z n°	Fz nor. kN	Fz max. kN	Coa (kN)	Mr (kN·m)	Ca (kN)	Cr (kN)	Weight kg
1 E.1100.32.00.C	1098	995	995	893	805	1016	30	845	30	1080	9	120	49.9	69.9	2260	553	538	349	165
2 E.1200.32.00.C	1200	1055	1055	993	905	1116	30	945	30	1180	10	118	55.5	77.6	2941	674	557	362	183
3 E.1300.32.00.C	1300	1155	1155	1093	1005	1216	36	1045	36	1280	10	128	55.5	77.6	3222	806	576	374	200
4 E.1400.32.00.C	1400	1255	1255	1193	1105	1316	42	1145	42	1380	10	138	55.5	77.6	3503	951	593	385	216
5 E.1500.32.00.C	1500	1355	1355	1293	1205	1416	42	1245	42	1480	10	148	55.5	77.6	3784	1107	610	396	234
6 E.1600.32.00.C	1600	1455	1455	1393	1305	1516	48	1345	48	1580	10	158	55.5	77.6	4065	1276	626	406	250

E 20.00.B

Standard version, ball Ø20mm, external geared, standard holes

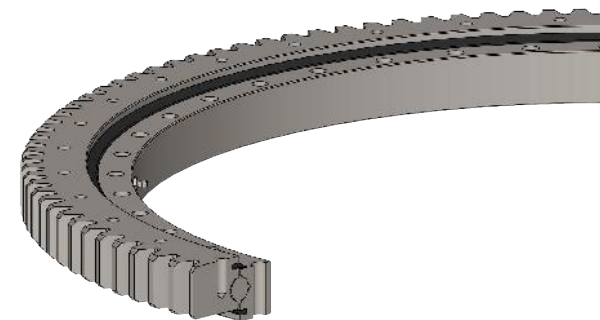
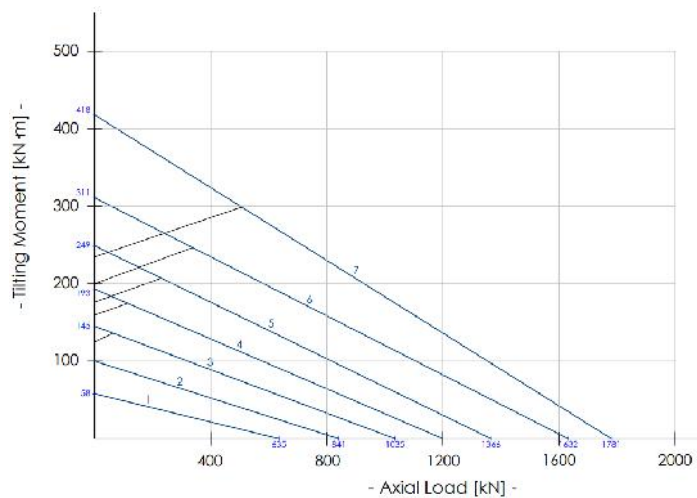
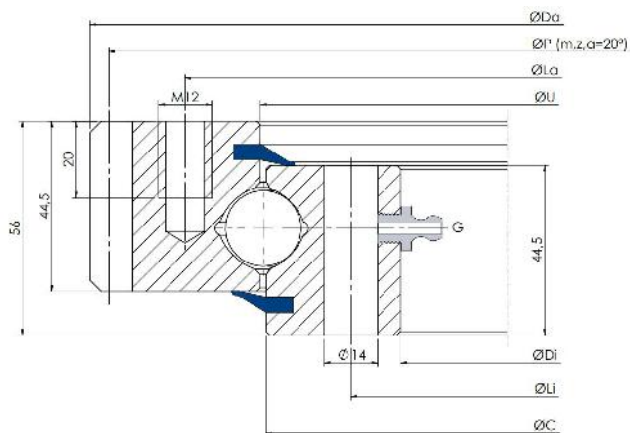

Slewing Ring Type	Dimensions				Fixing holes				Gear			Tooth Force		Static		Dynamic		Mass
	Da mm	U mm	C mm	Di mm	La mm	na n°	Li mm	ni n°	P mm	m	z n°	Fz nor. kN	Fz max. kN	Coa (kN)	Mr (kN·m)	Ca (kN)	Cr (kN)	Weight kg
1 E.505.20.00.B	503.3	415.5	412.5	342	455	20	368	24	495	5	99	17.8	24.9	635	58	197	128	31
2 E.650.20.00.B	640.3	545.5	542.5	472	585	28	498	32	630	6	105	21.2	29.7	869	103	218	142	43
3 E.750.20.00.B	742.3	645.5	642.5	572	685	32	598	36	732	6	122	21.2	29.7	1035	145	233	151	52
4 E.850.20.00.B	838.1	745.5	742.5	672	785	36	698	40	828	6	138	21.2	29.7	1186	191	246	160	59
5 E.950.20.00.B	950.1	845.5	842.5	772	885	36	798	40	936	8	117	28.2	39.6	1366	249	258	167	71
6 E.1050.20.00.B	1046.1	945.5	942.5	872	985	40	898	44	1032	8	129	28.2	39.6	1532	312	269	174	77
7 E.1200.20.00.B	1198.1	1095.5	1092.5	1022	1135	44	1048	48	1184	8	148	28.2	39.6	1781	418	284	184	91

E 25.00.B

Standard version, ball Ø25mm, external geared, standard holes

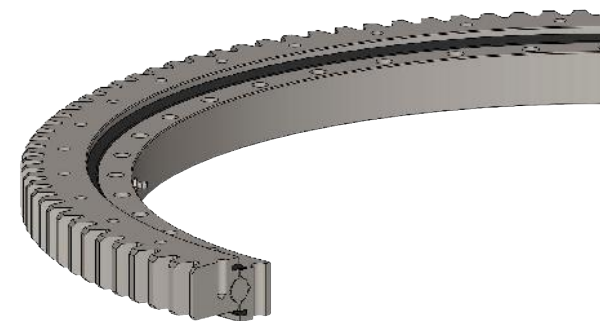
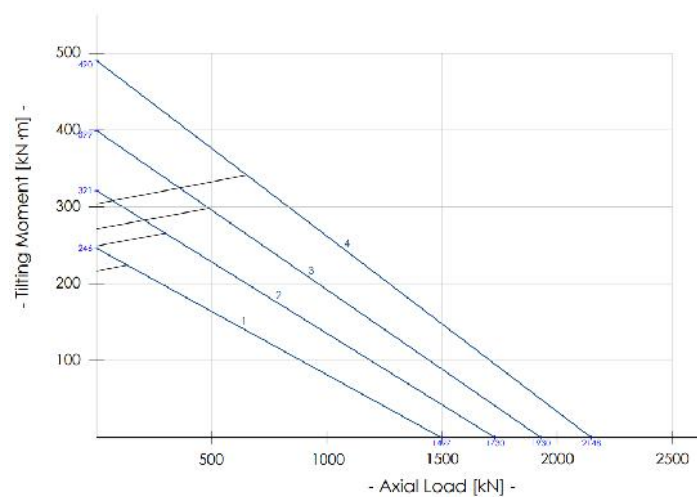
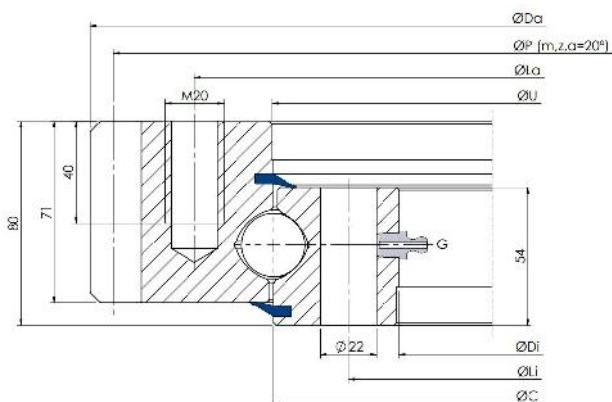

Slewing Ring Type	Dimensions				Fixing holes				Gear			Tooth Force		Static		Dynamic		Mass
	Da mm	U +IT8 mm	C mm	Di +IT8 mm	La mm	na n°	Li mm	ni n°	P mm	m	z n°	Fz nor. kN	Fz max. kN	Coa (kN)	Mr (kN·m)	Ca (kN)	Cr (kN)	Weight kg
1 E.900.25.00.B	898	755	754	657	816	24	695	24	882	9	98	50.8	71.1	1497	246	344	223	128
2 E.1000.25.00.B	997	855	854	757	916	28	795	28	981	9	109	50.8	71.1	1730	321	362	235	145
3 E.1100.25.00.B	1096	955	954	857	1016	30	895	30	1080	9	120	50.8	71.1	1930	399	376	244	155
4 E.1200.25.00.B	1198	1055	1054	957	1116	30	995	30	1180	10	118	55.5	77.6	2148	490	392	254	171

E 22.00.D

Special version, ball Ø22mm, external geared, special holes

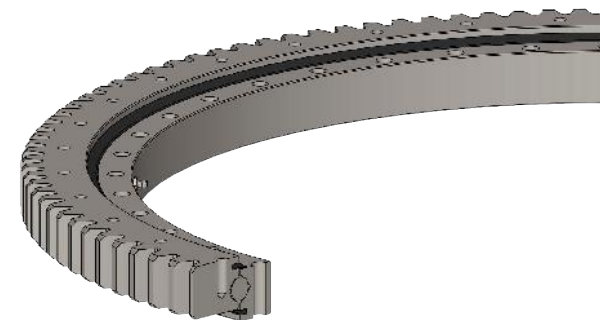
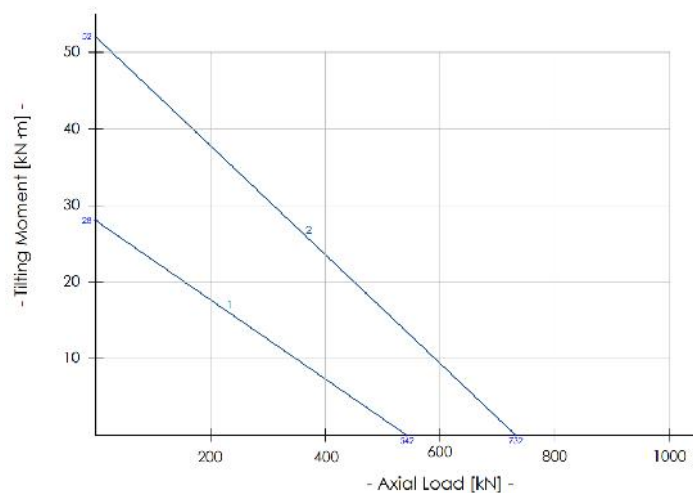
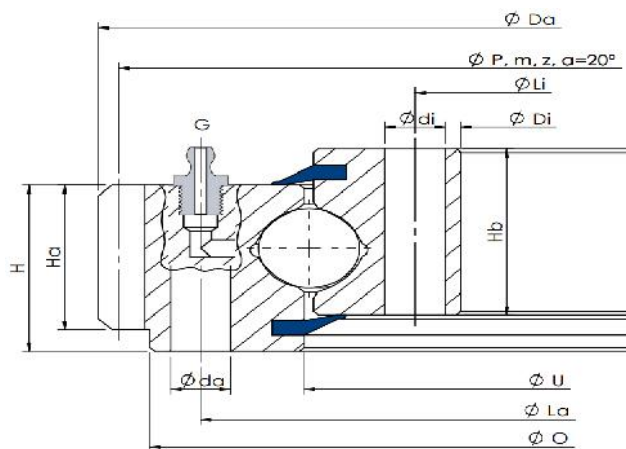

Slewing Ring Type	Dimensions								Fixing holes					Gear			Tooth Force		Mass
	Da mm	O mm	U mm	Di mm	Ha mm	Hb mm	H mm	La mm	na n°	da mm	Li mm	ni n°	di mm	P mm	m	z n°	Fz nor. kN	Fz max. kN	Weight kg
1 E.318.22.00.D.1	318	297	230	162	40	46	56	275	20	13	182	20-1	13	310.5	4.5	69	14.3	20	17
2 E.403.22.00.D.1	403.5	380	310	235	39	47	55	358	24	13	259	28-1	13	396	4.5	88	14.3	20	23

E 25.00.D

Special version, ball Ø25mm, external geared, special holes

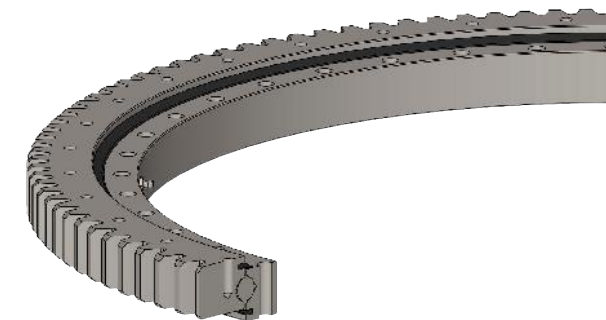
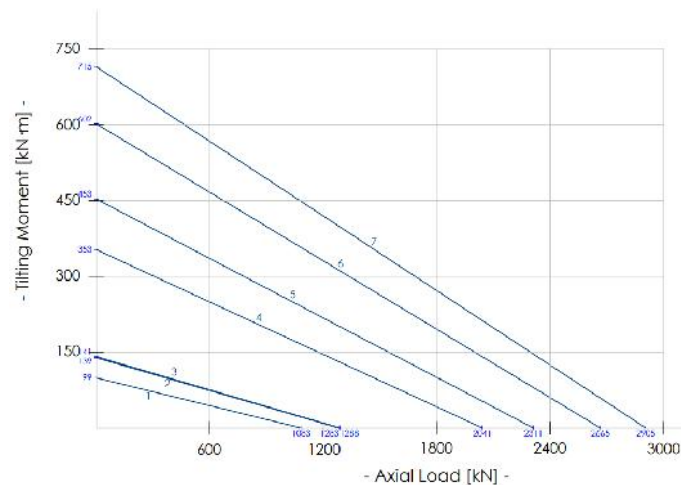
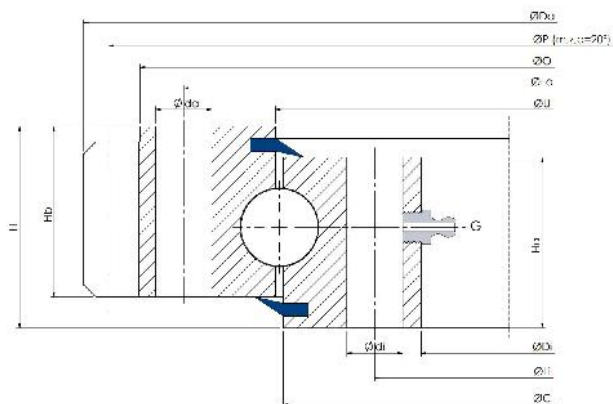

Slewing Ring Type	Dimensions							Fixing holes					Gear			Tooth Force		Mass	
	Da mm	O mm	U mm	Di mm	Ha mm	Hb mm	H mm	La mm	na n°	da mm	Li mm	ni n°	di mm	P mm	m	z n°	Fz nor. kN	Fz max. kN	Weight kg
1 E.535.25.00.D.1	535	495	401	306	55	63	75	466	18	20	336	18	20	520	8	65	34.2	47.9	65
2 E.589.25.15.D.1	589.5	565	475	384	40	63	75	540	36	16	410	36-1	16	580.5	4.5	129	14.9	21.4	60
3 E.595.25.00.D.6	595	565	477	382	50	55	65	540	18	17	410	18	17	585	5	117	19.5	27.3	58
4 E.864.25.00.D.5	864	835	771.5	680	57	65	82	800	24	M16	706	24	M16	852	6	142	26.9	37.7	85
5 E.972.25.00.D.3	972	942	854	766	58	60	70	912	36	M16	796	36	18	960	6	160	27.4	38.4	108
6 E.1080.25.00.D.5	1080	1042	987	895	62	64	82	1015	30	M16	922	30	M16	1064	8	133	40.4	56.5	120
7 E.1200.25.00.D.1	1200	1163	1078	982	50	55	65	1135	30	18	1012	30	18	1184	8	148	31.5	44.1	140

E 32.00.D

Special version, ball Ø32mm, external geared, special holes

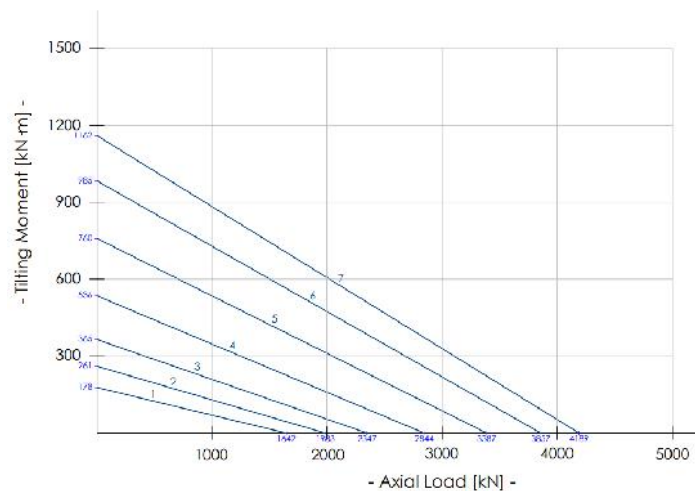
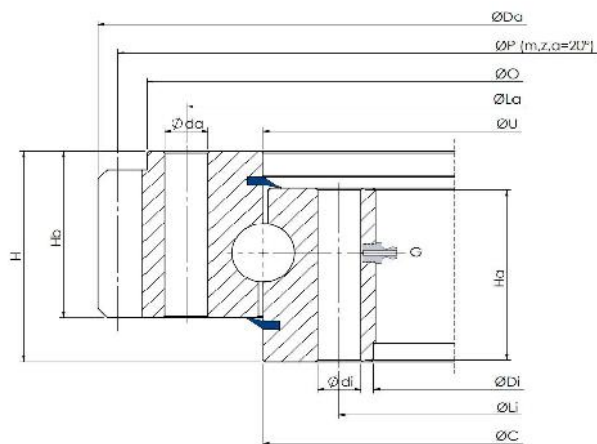

Slewing Ring Type	Dimensions							Fixing holes					Gear			Tooth Force		Mass	
	Da mm	O mm	U mm	Di mm	Ha mm	Hb mm	H mm	La mm	na n°	da mm	Li mm	ni n°	di mm	P mm	m	z n°	Fz nor. kN	Fz max. kN	Weight kg
1 E.595.32.00.D.1	595	565	475	382	65	75	88	540	24	18	410	24-1	18	585	5	117	24.5	35.5	80
2 E.695.32.15.D.1	695	670	574	480	42	64	77	640	36	18	508	36-1	18	685	5	137	18.3	26.1	77
3 E.816.32.00.D.1	816	781	682	574	65	70	90	753	18	22	604	18	22	792	6	132	29.4	41.2	120
4 E.980.32.00.D.1	979	932	845	718	65	82	100	893	36	22	753	36-1	22	940	10	94	52.1	72.9	167
5 E.1144.32.15.D.1	1144	1090	993	870	67	84	100	1050	36	22	910	36-1	22	1110	10	111	60.9	87.2	230
6 E.1289.32.15.D.1	1289.5	1240	1116	985	78	94	114	1198	40	22	1035	40	22	1250	10	125	64.7	92.7	330
7 E.1380.32.15.D.1	1380	1330	1212	1100	80	94	114	1290	36	22	1135	36	22	1360	10	136	67.4	97.2	335

E 2.XX.00.D

Double row version, double ball different \emptyset in mm, external geared, special holes

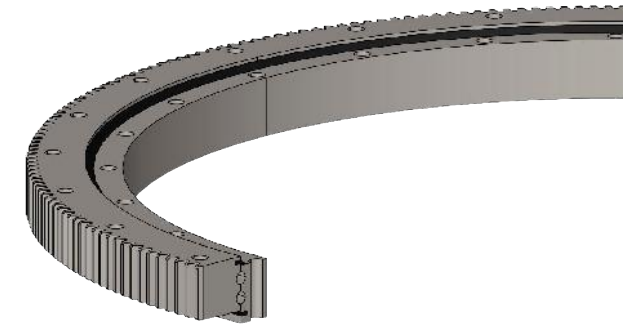
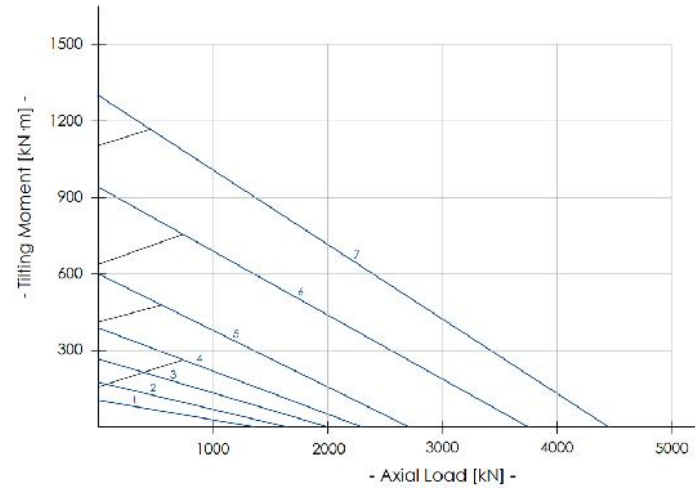
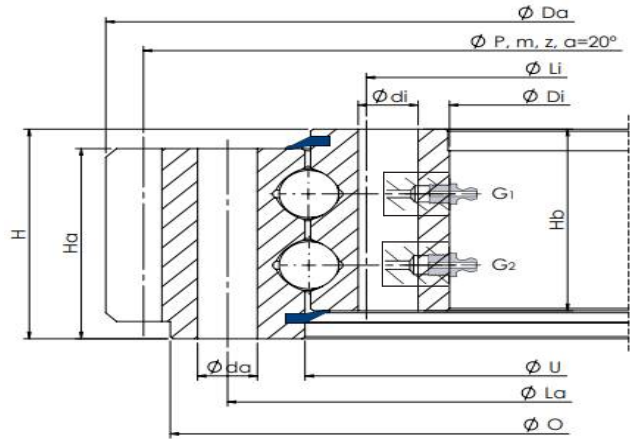

Slewing Ring Type	Dimensions							Fixing holes					Gear			Tooth Force		Mass		
	Da mm	O mm	U mm	Di mm	Ha mm	Hb mm	H mm	La mm	na n°	da mm	Li mm	ni n°	di mm	P mm	m	z n°	Fz nor. kN	Fz max. kN	Weight kg	
1	E.504.2.25.00.D.6	504	466	387	300	75	87	95	436	16	17	330	16	17	488	8	61	31	62	65
2	E.608.2.25.10.D.6	608	570	487	382	78	87	95	540	24	17	410	24	17	592	8	74	40	80	84
3	E.712.2.25.12.D.6	712	670	577	470	75	88	98	640	24	17	508	24	20	696	8	87	41	82	103
4	E.1079.2.20.12.D.3-V	1079	972	972	893	70	80	90	1015	30	M16	922	30	18	1048	8	131	42	84	140
5	E.1080.2.22.00.D.6	1080	1042	970	893	76	83	92	1015	30	17	992	30	17	1064	8	133	32	64	150
6	E.1200.2.25.00.D.1	1200	1163	1079	976	77	88	98	1135	36	19	1012	36	19	1184	8	148	32	64	210

E XX.00.D-RV

Cross row version, different rollers \emptyset in mm, external geared, special holes

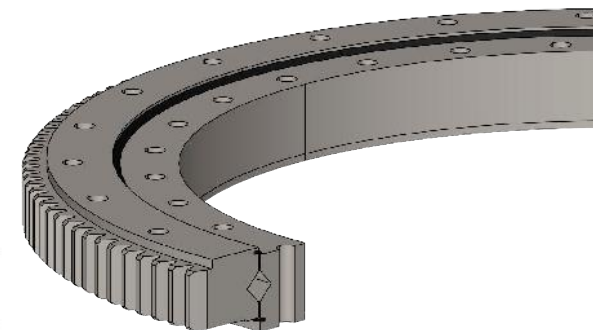
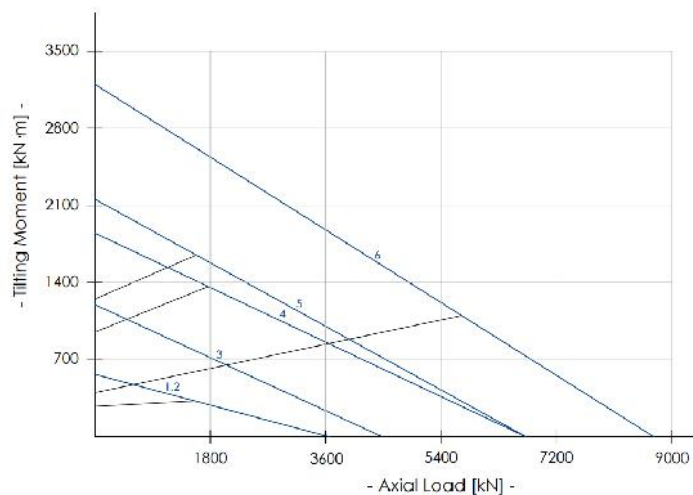
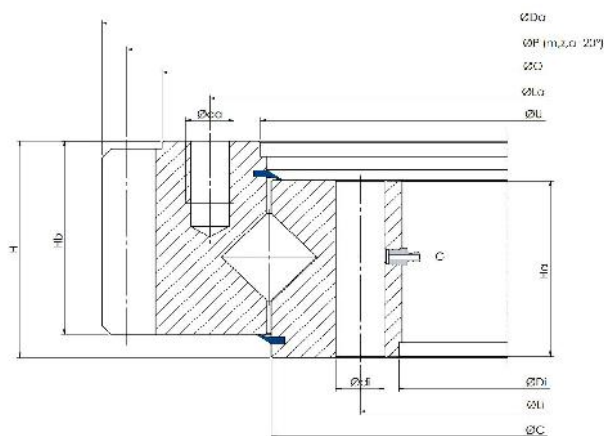

Slewing Ring Type	Dimensions							Fixing holes					Gear			Tooth Force		Mass	
	Da mm	O mm	U mm	Di mm	Ha mm	Hb mm	H mm	La mm	na n°	da mm	Li mm	ni n°	di mm	P mm	m	z n°	Fz nor. kN	Fz max. kN	Weight kg
1 E.1144.30.12.D.1-RV	1144	1090	993	870	84	67	100	1050	18	22	910	SC*	22	1110	10	111	58	116	230
2 E.1144.30.12.D.3-RV	1144	1090	993	870	84	67	100	1050	SC*	22	910	SC*	22	1122	11	102	60	120	230
3 E.1390.30.15.D.1-R	1390	1237	1237	1115	89	85	105	1290	30	M20	1150	30	22	1368	12	114	82	164	329
4 E.1476.45.15.D.1-RV	1476	1415	1252.5	1085	100	77	110	1350	24	26	1150	28	26	1440	10	144	68	136	475
5 E.1604.50.10.D.1-RV	1604	1550	1394	1208	116	75	128	1500	24	29	1280	SC*	29	1570	10	157	55	110	606
6 E.1805.45.17.D.3-R	1805	1730	1608	1437	120	115	140	1671	60	M27	1485	60	30	1744	16	109	167	334	750

SC* = Drilling not equi-spaced

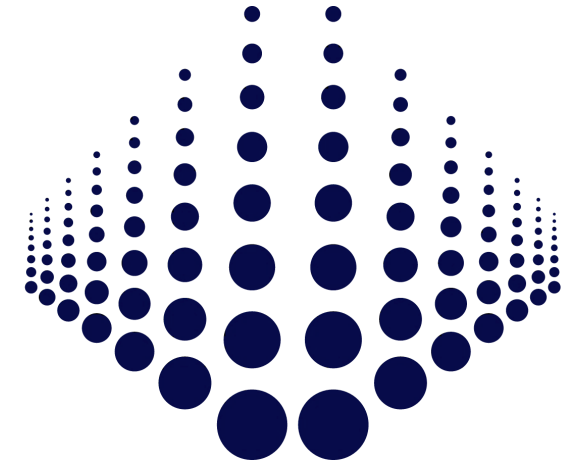
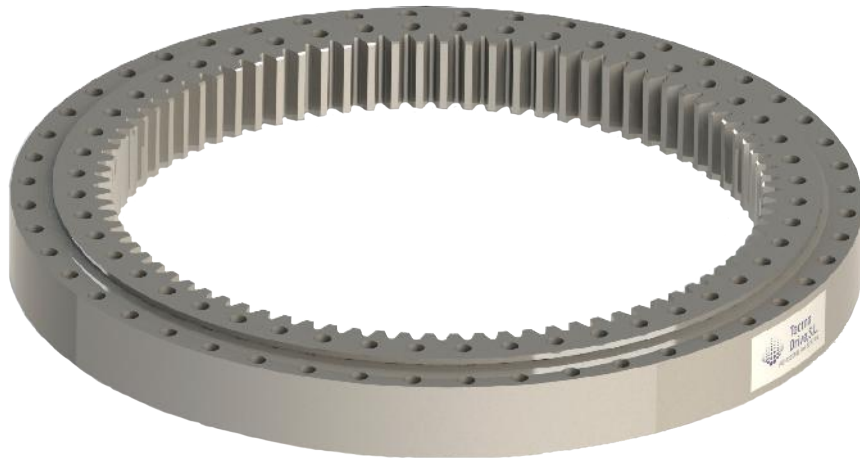

MODEL INTERNAL GEAR

I 20.00.C

Light version, ball Ø20mm, internal geared, standard holes

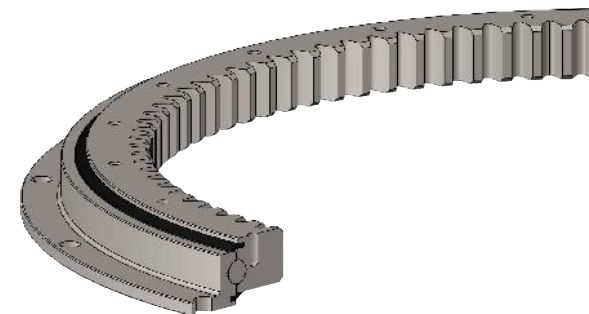
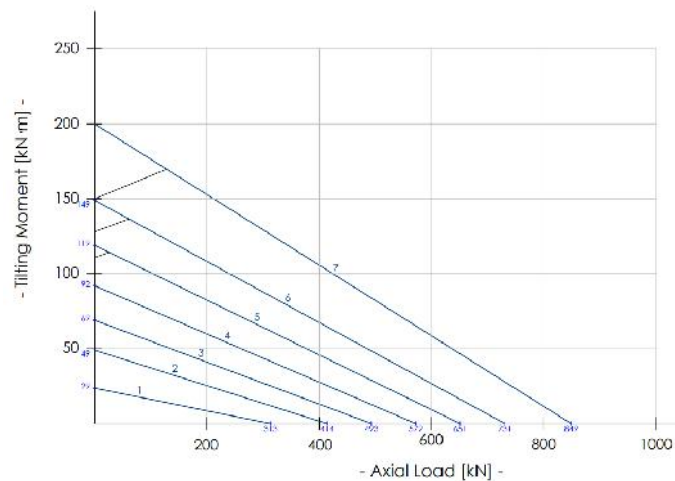
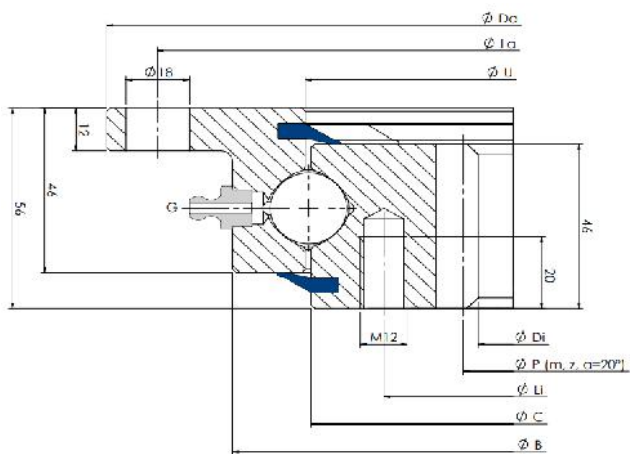

Slewing Ring Type	Dimensions					Fixing holes				Gear			Tooth Force		Static		Dynamic		Mass
	Da mm	B mm	U mm	C mm	Di mm	La mm	na n°	Li mm	ni n°	P mm	m	z n°	Fz nor. kN	Fz max. kN	Coa (kN)	Mr (kN·m)	Ca (kN)	Cr (kN)	Weight kg
1 I.505.20.00.C	518	453	415.5	412.5	326.5	490	8	375	12	335	5	67	17.7	24.7	313	29	197	128	27
2 I.650.20.00.C	648	583	545.5	542.5	445.2	620	10	505	16	456	6	76	21.4	30	414	49	218	142	37.5
3 I.750.20.00.C	748	683	645.5	642.5	547.2	720	12	605	18	558	6	93	21.4	30	493	69	233	151	44.5
4 I.850.20.00.C	848	783	745.5	742.5	649.2	820	12	705	20	660	6	110	21.4	30	572	92	246	160	51
5 I.950.20.00.C	948	883	845.5	842.5	737.6	920	14	805	20	752	8	94	28.5	39.9	651	119	258	167	61
6 I.1050.20.00.C	1048	983	945.5	942.5	841.6	1020	16	905	22	856	8	107	28.5	39.9	731	149	269	174	65
7 I.1200.20.00.C	1198	1133	1095.5	1092.5	985.6	1170	16	1055	24	1000	8	125	28.5	39.9	849	200	284	184	80

I 32.00.C

Light version, ball Ø32mm, internal geared, standard holes

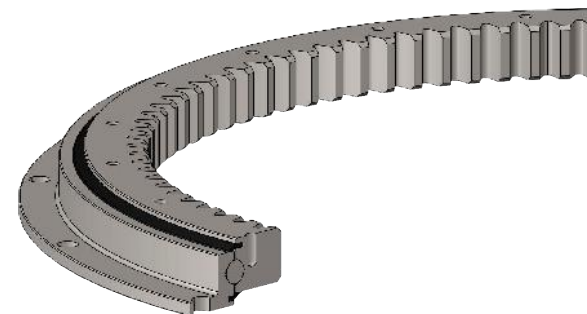
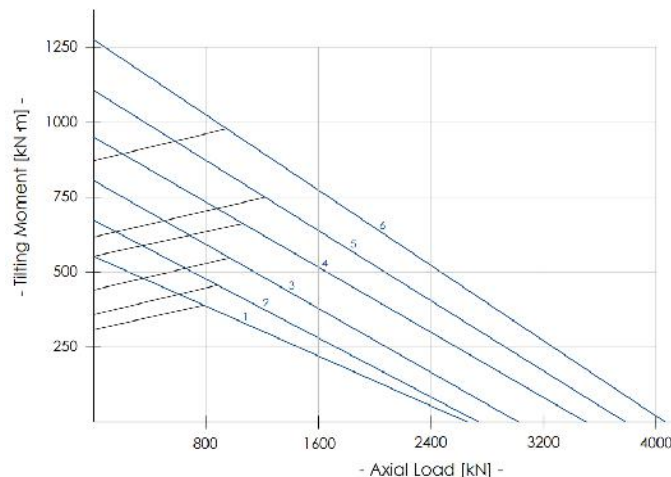
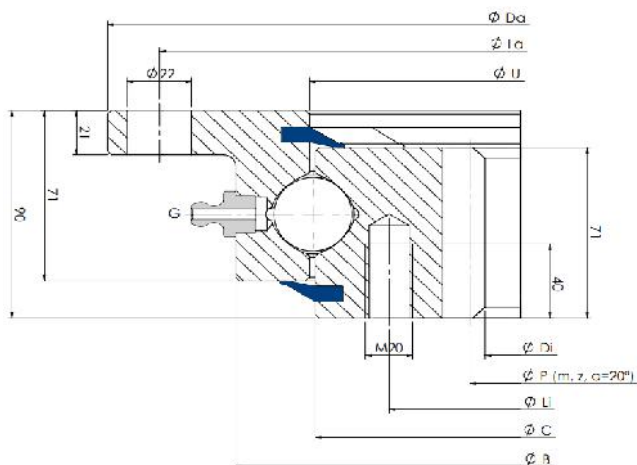

Slewing Ring Type	Dimensions					Fixing holes				Gear			Tooth Force		Static		Dynamic		Mass	
	Da mm	B mm	U mm	C mm	Di mm	La mm	na n°	Li mm	ni n°	P mm	m	z n°	Fz nor. kN	Fz max. kN	Coa (kN)	Mr (kN·m)	Ca (kN)	Cr (kN)	Weight kg	
1	I.1100.32.00.C	1100	1017	955	955	810	1060	30	894	30	830	10	83	56.8	84.2	2660	553	538	349	159
2	I.1200.32.00.C	1200	1117	1055	1055	910	1160	30	994	30	930	10	93	56.8	84.2	2941	674	557	362	176
3	I.1300.32.00.C	1300	1217	1155	1155	1010	1260	36	1094	36	1030	10	103	56.8	84.2	3222	806	576	374	192
4	I.1400.32.00.C	1400	1317	1255	1255	1110	1360	42	1194	42	1130	10	113	56.8	84.2	3503	951	593	385	208
5	I.1500.32.00.C	1500	1417	1355	1355	1210	1460	42	1294	42	1230	10	123	56.8	84.2	3784	1107	610	396	226
6	I.1600.32.00.C	1600	1517	1455	1455	1310	1560	48	1394	48	1330	10	133	56.8	84.2	4065	1276	626	406	243

I 20.00.B

Standard version, ball Ø20mm, internal geared, standard holes

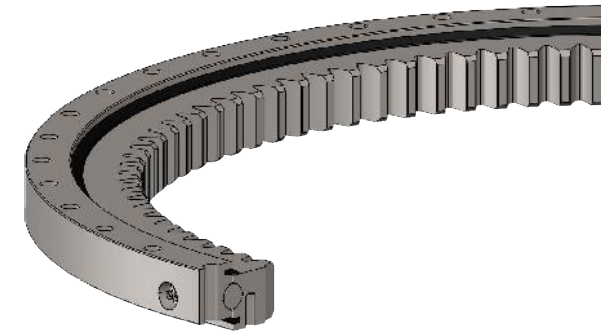
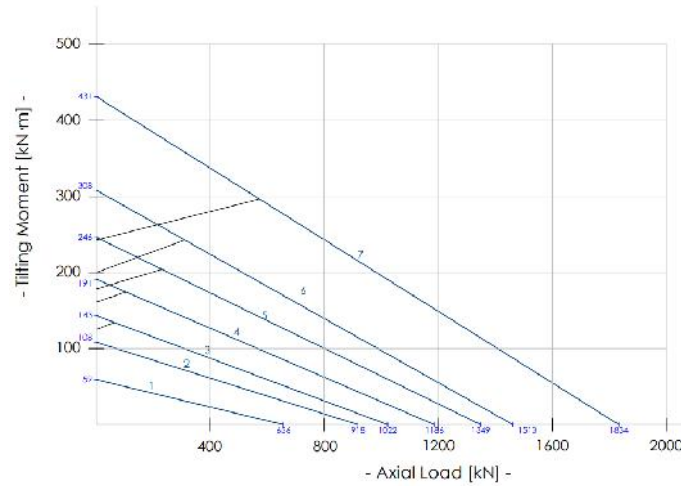
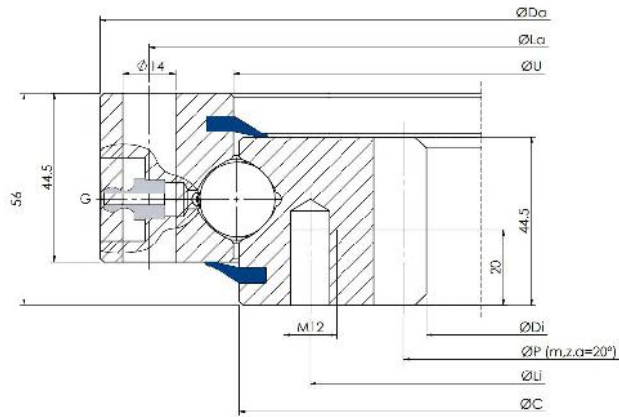

Slewing Ring Type	Dimensions				Fixing holes				Gear			Tooth Force		Static		Dynamic		Mass	
	Da mm	U mm	C mm	Di mm	La mm	na n°	Li mm	ni n°	P mm	m	z n°	Fz nor. kN	Fz max. kN	Coa (kN)	Mr (kN-m)	Ca (kN)	Cr (kN)	Weight kg	
1	I.486.20.00.B	486	415.5	412.5	325	460	24	375	24	335	5	67	17.7	24.7	656	59	197	128	31
2	I.616.20.00.B	616	545.5	542.5	444	590	32	505	32	456	6	76	21.4	30	918	108	218	142	42
3	I.716.20.00.B	716	645.5	642.5	546	690	36	605	36	558	6	93	21.4	30	1022	143	233	151	50
4	I.816.20.00.B	816	745.5	742.5	648	790	40	705	40	660	6	110	21.4	30	1186	191	246	160	58
5	I.916.20.00.B	916	845.5	842.5	736	890	40	805	40	752	8	94	28.5	39.9	1349	246	258	167	69
6	I.1016.20.00.B	1016	945.5	942.5	840	990	44	905	44	856	8	107	28.5	39.9	1513	308	269	174	76
7	I.1166.20.00.B	1166	1095.5	1092.5	984	1140	48	1055	48	1000	8	125	28.5	39.9	1834	431	284	184	91

I 25.00.B

Standard version, ball Ø25mm, internal geared, standard holes

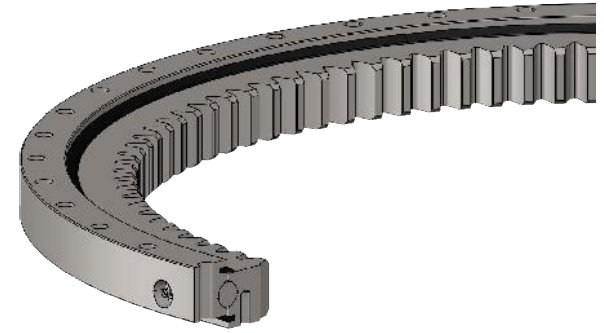
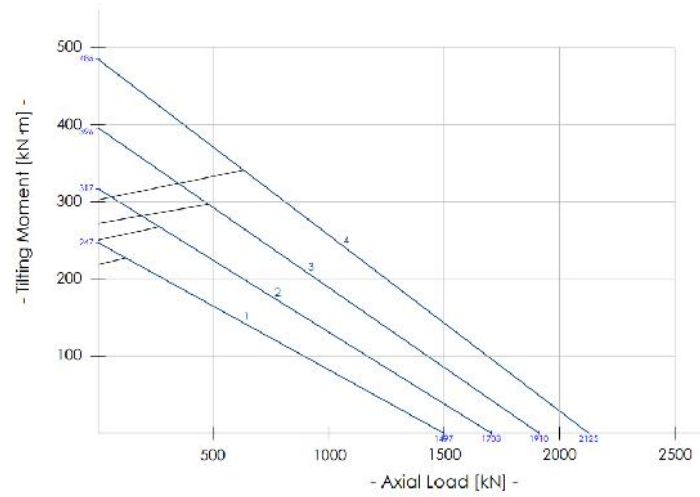
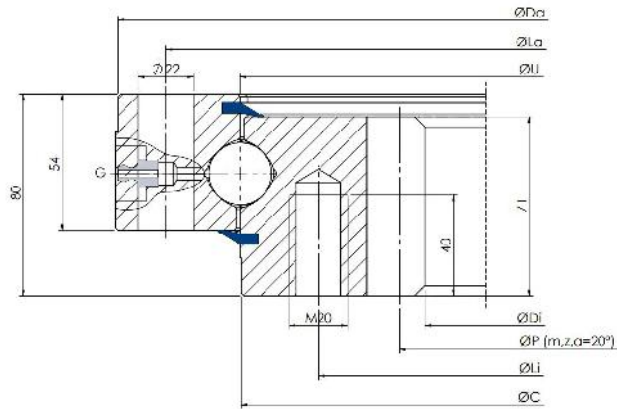

Slewing Ring Type	Dimensions				Fixing holes				Gear			Tooth Force		Static		Dynamic		Mass
	Da -IT8 mm	U mm	C -IT8 mm	Di mm	La mm	na n°	Li mm	ni n°	P mm	m	z n°	Fz nor. kN	Fz max. kN	Coa (kN)	Mr (kN·m)	Ca (kN)	Cr (kN)	Weight kg
1 I.855.25.00.B	853	756	755	610	815	24	694	24	630	10	63	55.5	77.7	1497	247	344	223	119
2 I.955.25.00.B	953	856	855	710	915	28	794	28	730	10	73	55.5	77.7	1703	317	362	235	137
3 I.1055.25.00.B	1053	956	955	810	1015	30	894	30	830	10	83	55.5	77.7	1910	396	376	244	149
4 I.1155.25.00.B	1153	1056	1055	910	1115	30	994	30	930	10	93	55.5	77.7	2125	485	391	254	165

I 25.00.D

Special version, ball Ø25mm, internal geared, special holes

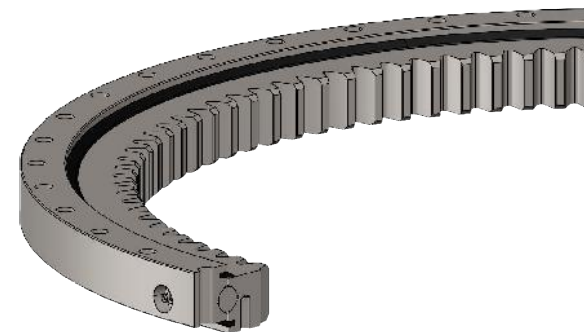
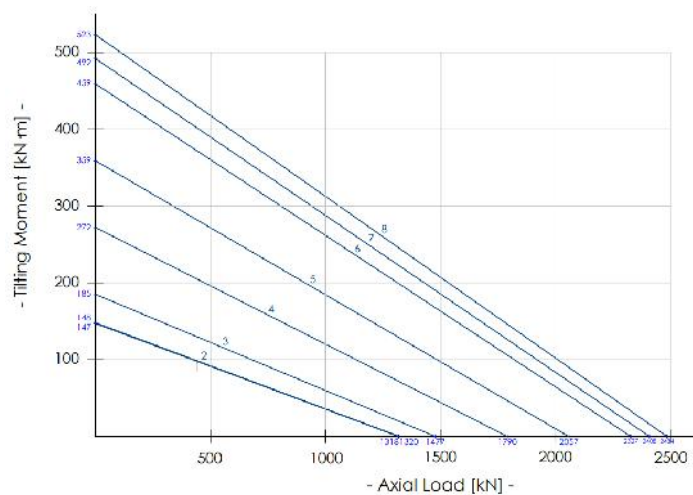
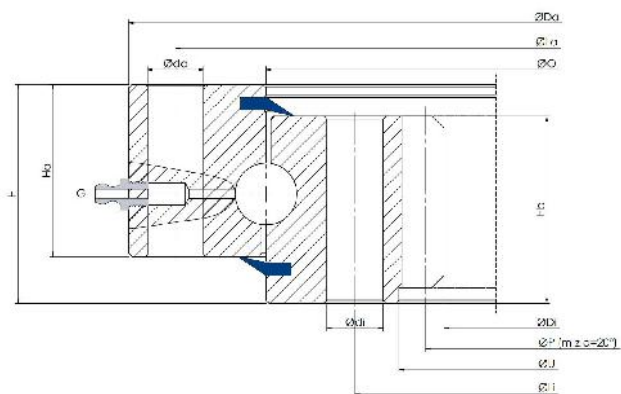

Slewing Ring Type	Dimensions								Fixing holes					Gear			Tooth Force		Mass
	Da mm	O mm	U mm	Di mm	Ha mm	Hb mm	H mm	La mm	na n°	da mm	Li mm	ni n°	di mm	P mm	m	z n°	Fz nor. kN	Fz max. kN	Weight kg
1 I.562.25.15.D.1	560	489	418	385	43	50	60	538	30	14	440	30	14	396	6	66	25.5	36.5	41
2 I.570.25.00.D.1	570	488	410	378	55	55	70	540	18	18	436	18	18	390	6	65	25.7	35.9	54
3 I.635.25.00.D.3.V	635	547	467	439.5	50	50	60	605	24	15	490	16	M16	444	6	74	30.9	46	57
4 I.750.25.00.D.1	750	663	575	546	55	55	70	720	20	18	605	20	18	558	6	93	26.4	37	76
5 I.850.25.00.D.1	850	762	677	648	55	55	70	820	24	18	705	24	18	660	6	110	24.9	36	91
6 I.950.25.00.D.1	950	862	775	736	55	55	70	920	30	18	805	30	18	752	8	94	33.3	46.6	108
7 I.980.25.00.D.3	975	892	892	784	72	66	84	944	36	18	850	36	M16	800	8	100	43	62	135
8 I.1015.25.15.D.1	1015	920	824	784	67	66	82	980	40	18	860	40	18	800	8	100	43	62	143

I 32.00.D

Special version, ball Ø32mm, internal geared, special holes

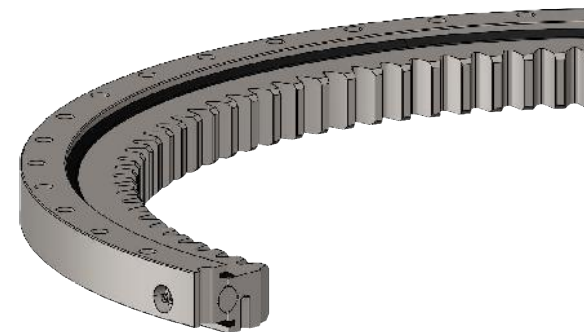
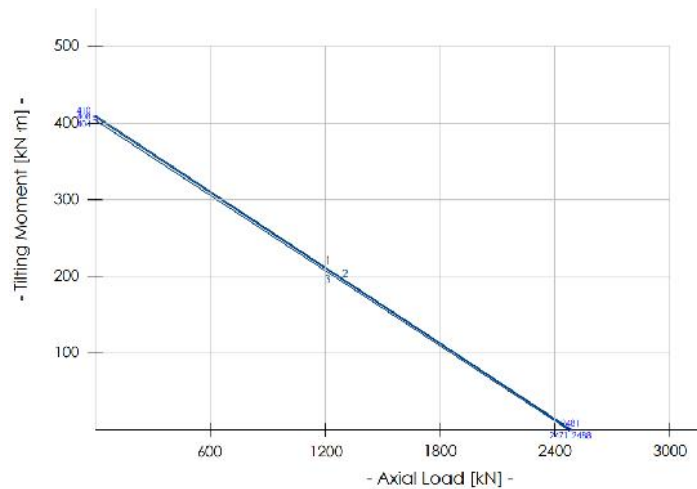
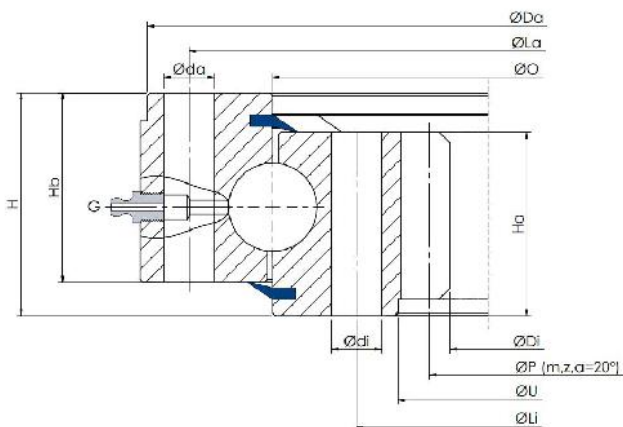

Slewing Ring Type	Dimensions							Fixing holes					Gear			Tooth Force		Mass	
	Da mm	O mm	U mm	Di mm	Ha mm	Hb mm	H mm	La mm	na n°	da mm	Li mm	ni n°	di mm	P mm	m	z n°	Fz nor. kN	Fz max. kN	Weight kg
1 I.810.32.00.D.1	805	718	630	601	60	68	80	780	20	18	660	20	18	612	6	102	28.2	40.3	110
2 I.815.32.10.D.1	810	720	630	593	60	68	80	780	30	18	660	30	18	608	8	76	37.9	53.1	110
3 I.816.32.00.D.1	815	715	605	568.9	67	75	90	785	18	17	640	18	17	574	7	82	37	51.8	143

E 2.XX.00.D

Double row version, double ball different \emptyset in mm, internal geared, special holes

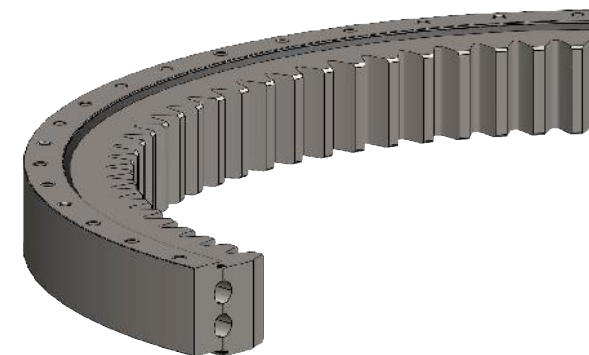
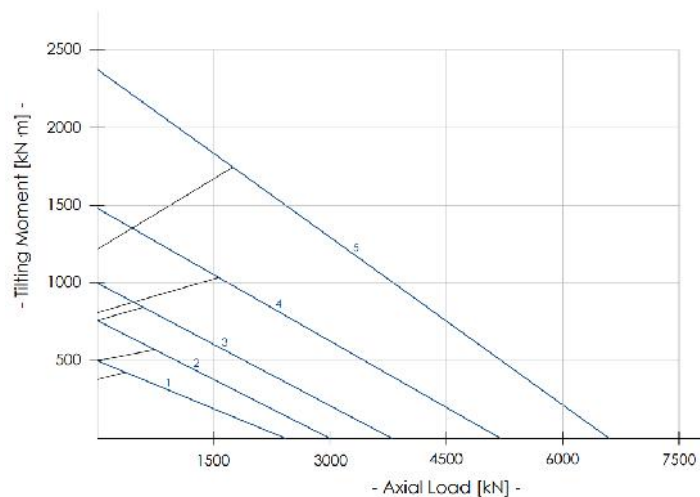
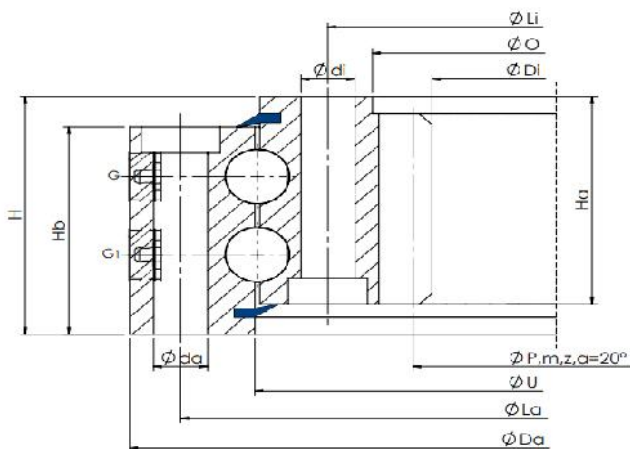

Slewing Ring Type	Dimensions							Fixing holes					Gear			Tooth Force		Mass	
	Da mm	O mm	U mm	Di mm	Ha mm	Hb mm	H mm	La mm	na n°	da mm	Li mm	ni n°	di mm	P mm	m	z n°	Fz nor. kN	Fz max. kN	Weight kg
1 I.973.2.22.00.D.6	973	899	820	786	80	88	97	944	36	17	850	36	17	800	8	100	36.2	72.4	141
2 I.1165.2.22.00.D.6	1165	1089	1010	962	83	88	98	1134	36	17	1040	36	17	980	10	98	45	90	187
3 I.1200.2.25.00.D.6	1200	1102	1010	963.5	88	96	110	1160	36	21	1040	36	21	980	10	98	69	99	230
4 I.1346.2.30.05.D.6	1345	1225	1115	1061.6	88	98	108	1290	48	21	1150	48	21	1080	10	108	68.9	137.8	326
5 I.1750.2.30.20.D.6	1750	1617	1470	1418	98	110	120	1705	48	25	1525	48	25	1440	12	120	94	140	564

E XX.00.D-RV

Cross row version, different rollers \emptyset in mm, internal geared, special holes

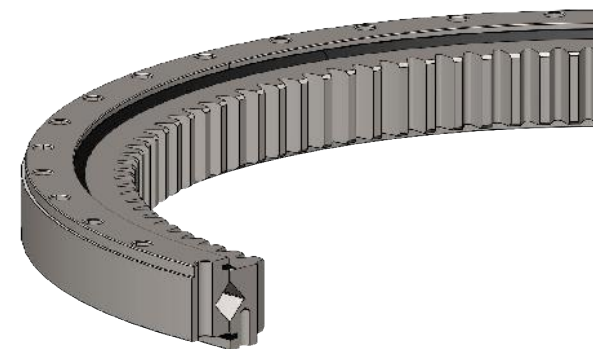
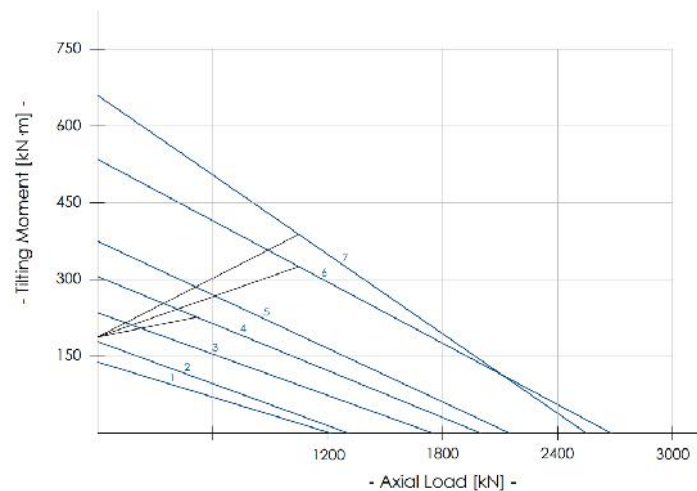
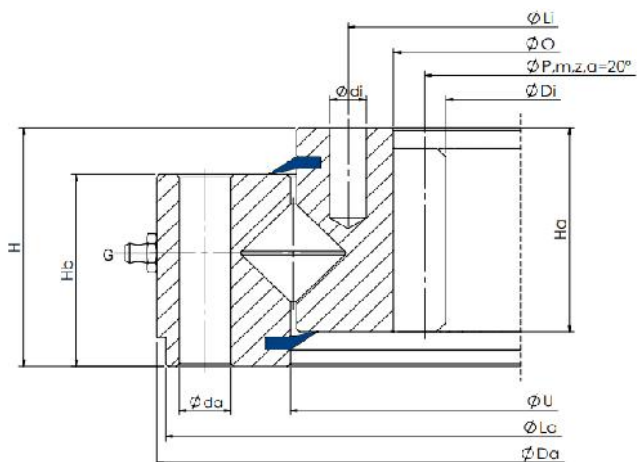

Slewing Ring Type	Dimensions								Fixing holes					Gear			Tooth Force		Mass
	Da mm	O mm	U mm	Di mm	Ha mm	Hb mm	H mm	La mm	na n°	da mm	Li mm	ni n°	di mm	P mm	m	z n°	Fz nor. kN	Fz max. kN	Weight kg
1 I.1165.25.12.D.3-RV	1165	1077.5	1010	961	62	75	90	1134	36	18	1040	36	M16	980	10	98	40	80	155
2 I.1251.30.12.D.1-RV	1250	1142	1142	979	75	75	91	1212	40	22	1068	36	22	990	10	99	58	116	240
3 I.1346.30.15.D.1-RV	1345	1222	1115	1067	75	85	105	1290	36	22	1150	42	22	1080	10	108	58	116	300
4 I.1460.30.12.D.1-RV	1460	1350	1230	1173	80	84	102	1425	36	22	1270	36	22	1176	12	98	74	148	365
5 I.1530.40.12.D.1-RV	1530	1410	1240	1186	90	107	130	1480	36	26	1290	36	26	1200	10	120	70	140	560
6 I.1770.50.17.D.1-RV	1760	1608	1440	1375	110	125	150	1710	48	31	1500	48	31	1400	14	100	120	240	845
7 I.2025.50.15.D.1-RV	2025	1863	1695	1619	115	118	140	1970	36	30	1780	36	30	1616	16	101	135	270	960

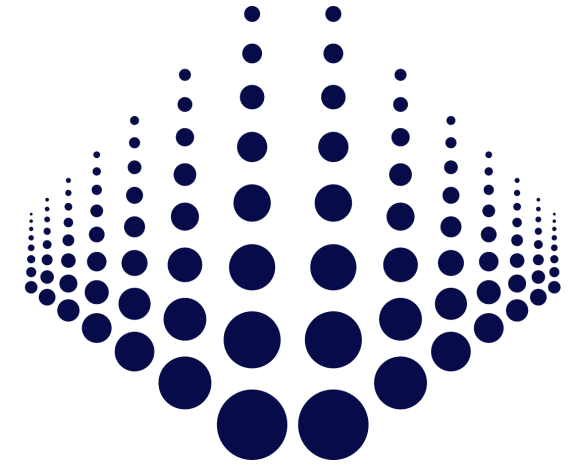

SPECIAL MODELS

SD 14.00.B.R-ZT

Cross row version, rollers $\varnothing 14$ mm, ungeared, through holes

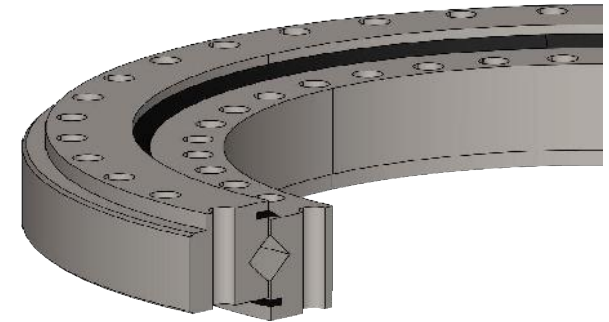
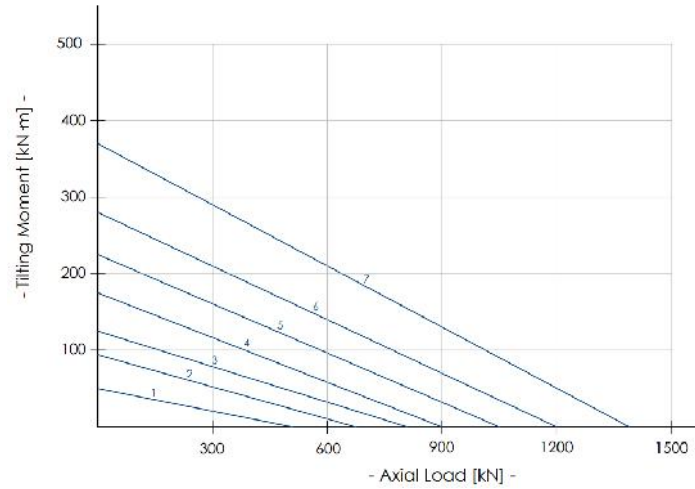
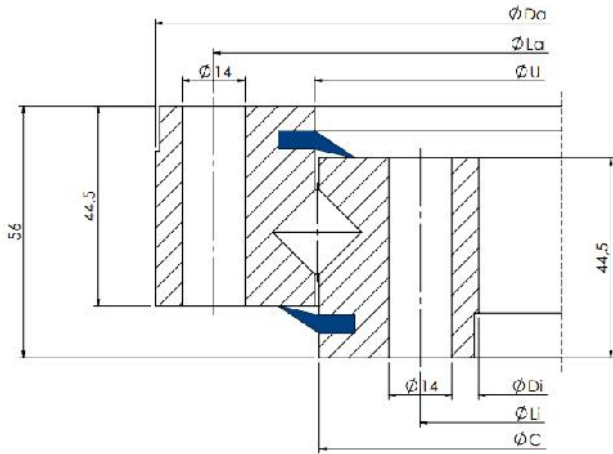

Slewing Ring Type	Dimensions				Fixing holes				Static		Dynamic		Mass
	Da -1T7 mm	U mm	C mm	Di +1T7 mm	La mm	na n°	Li mm	ni n°	Coa (kN)	Mr (kN·m)	Ca (kN)	Cr (kN)	Weight kg
1 SD.486.14.00.B.R-ZT	484	415.5	412.5	344	460	24	369	24	635	58	197	128	29
2 SD.616.14.00.B.R-ZT	614	545.5	542.5	474	590	32	498	32	841	100	219	142	37
3 SD.716.14.00.B.R-ZT	714	645.5	642.5	574	690	36	598	36	1035	145	233	151	44
4 SD.816.14.00.B.R-ZT	814	745.5	742.5	674	790	40	698	40	1201	193	246	160	52
5 SD.916.14.00.B.R-ZT	914	845.5	842.5	774	890	40	798	40	1366	249	258	167	60
6 SD.1016.14.00.B.R-ZT	1014	945.5	942.5	874	990	44	898	44	1632	311	269	174	67
7 SD.1166.14.00.B.R-ZT	1164	1095.5	1092.5	1024	1140	48	1048	48	1781	418	284	184	77

E 14.00.B.R-ZT

Cross row version, rollers $\varnothing 14$ mm, external geared, through holes

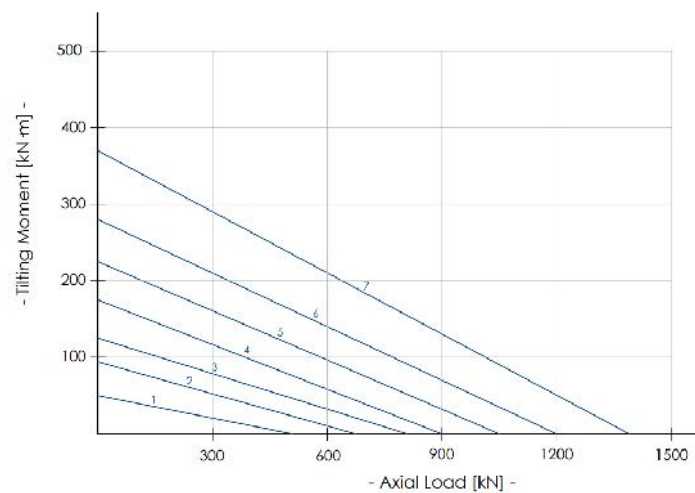
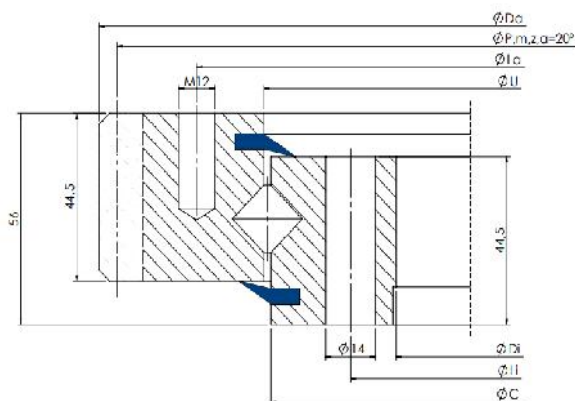
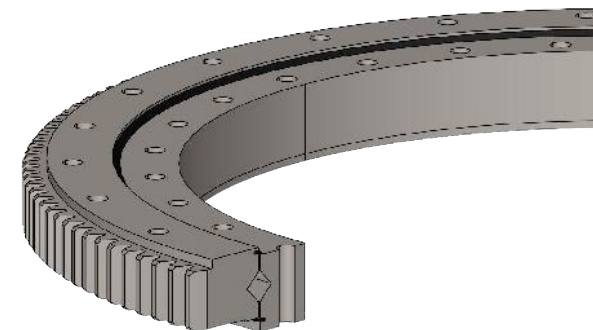

Slewing Ring Type	Dimensions				Fixing holes				Gear			Tooth Force		Static		Dynamic		Mass
	Da mm	U +1T7 mm	C mm	Di +1T7 mm	La mm	na n°	Li mm	ni n°	P mm	m	z n°	Fz nor. kN	Fz max. kN	Coa (kN)	Mr (kN·m)	Ca (kN)	Cr (kN)	Weight kg
1 E.505.14.00.B.R-ZT	503.3	417	412.5	344	455	20	368	24	495	5	99	17.8	24.9	635	58	197	128	31
2 E.650.14.00.B.R-ZT	640.3	547	542.5	474	585	28	498	32	630	6	105	21.2	29.7	869	103	218	142	43
3 E.750.14.00.B.R-ZT	742.3	647	642.5	574	685	32	598	36	732	6	122	21.2	29.7	1035	145	233	151	52
4 E.850.14.00.B.R-ZT	838.1	747	742.5	674	785	36	698	40	828	6	138	21.2	29.7	1186	191	246	160	59
5 E.950.14.00.B.R-ZT	950.1	847	842.5	774	885	36	798	40	936	8	117	28.2	39.6	1366	249	258	167	71
6 E.1050.14.00.B.R-ZT	1046.1	947	942.5	874	985	40	898	44	1032	8	129	28.2	39.6	1532	312	269	174	77
7 E.1200.14.00.B.R-ZT	1198.1	1097	1092.5	1024	1135	44	1048	48	1184	8	148	28.2	39.6	1781	418	284	184	91

I 14.00.B.R-ZT

Cross row version, rollers $\varnothing 14$ mm, internal geared, through holes

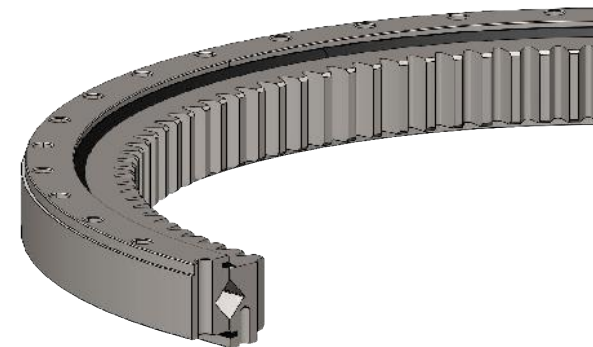
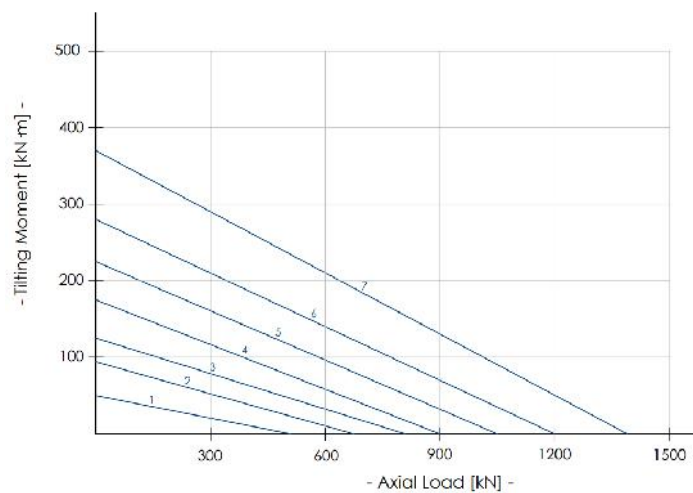
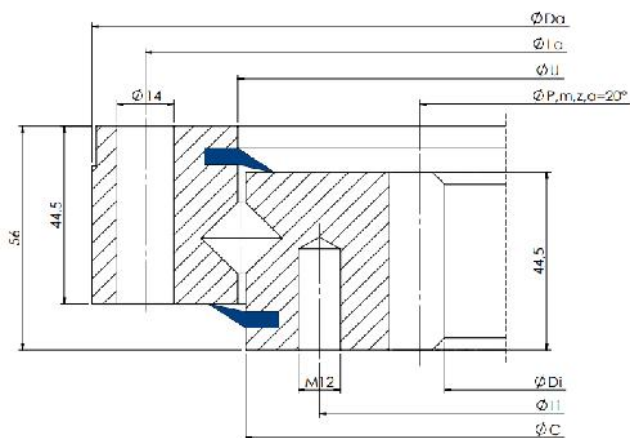

Slewing Ring Type	Dimensions				Fixing holes				Gear			Tooth Force		Static		Dynamic		Mass
	Da +1T7 mm	U mm	C +1T7 mm	Di mm	La mm	na n°	Li mm	ni n°	P mm	m	z n°	Fz nor. kN	Fz max. kN	Coa (kN)	Mr (kN·m)	Ca (kN)	Cr (kN)	Weight kg
1 I.486.14.00.B.R-ZT	484	415.5	411	325	460	24	375	24	335	5	67	17.7	24.7	656	59	197	128	31
2 I.616.14.00.B.R-ZT	614	545.5	541	444	590	32	505	32	456	6	76	21.4	30	918	108	218	142	42
3 I.716.14.00.B.R-ZT	714	645.5	641	546	690	36	605	36	558	6	93	21.4	30	1022	143	233	151	50
4 I.816.14.00.B.R-ZT	814	745.5	741	648	790	40	705	40	660	6	110	21.4	30	1186	191	246	160	58
5 I.916.14.00.B.R-ZT	914	845.5	841	736	890	40	805	40	752	8	94	28.5	39.9	1349	246	258	167	69
6 I.1016.14.00.B.R-ZT	1014	945.5	941	840	990	44	905	44	856	8	107	28.5	39.9	1513	308	269	174	76
7 I.1166.14.00.B.R-ZT	1164	1095.5	1091	984	1140	48	1055	48	1000	8	125	28.5	39.9	1834	431	284	184	91

Technical form

Customer details :				
Company :				
Contact person :	Address:			
Phone number :				
E-mail :				
Material details :				
Application description :				
New application :	Yes <input type="checkbox"/> No <input type="checkbox"/>			
Exchangeable with existing :	Yes <input type="checkbox"/> No <input type="checkbox"/>			
Slewing ring denomination :	Ref: _____			
Slew drive denomination :	Ref: _____			
Working position :	Vertical <input type="checkbox"/> Horizontal <input type="checkbox"/> Inclined <input type="checkbox"/>			
Hours of work:	Cycles: _____			
Speed :	rpm _____ Maximal angle of rotation : _____			
Slewing direction :	One direction only <input type="checkbox"/> Alternating direction <input type="checkbox"/>			
Continous rotation without interruption	<input type="checkbox"/> Interrupted rotation <input type="checkbox"/>			
Load :				
Loads acting	Normal load	Maximum load	Test load	Extreme load
Axial load	Fax [kN]			
Radial	Frad [kN]			
Tilting moment	MK[kNm]			
Duty cycle	E (%)			
Normal speed	n[min^{-1}]			
Maximum speed	n _{max} [min-]			
Dimensions (mm / inch)				
Outside diameter	Inside diameter	Overall height	Raceway diameter	
Gear description :				
External gear <input type="checkbox"/>	Internal gear <input type="checkbox"/>	No gearing <input type="checkbox"/>		
Tooth from :	Modul / DP:	Contact angle :		
	Pinion	Geared ring		
Number of teeth -z				
Profile correction -xm				
Gear width -b				
Addendum coefficient x				
Center distance				
Gear teeh hardened	yes <input type="checkbox"/> no <input type="checkbox"/>			
Type of hardening	tooth flanks <input type="checkbox"/>	tooth contour <input type="checkbox"/>		
Tooth flank direction :	right <input type="checkbox"/>	left <input type="checkbox"/>		
Additional requirements :				

Type of material		
Material	<input type="checkbox"/> not specified	<input type="checkbox"/> C45
Heat treatment	<input type="checkbox"/> normalized	<input type="checkbox"/> quenched and tempered
		<input type="checkbox"/> 42CrMo4

Special requirements :		
Seals are required	<input type="checkbox"/> Extremely dirty	<input type="checkbox"/> Oil lubrication
		<input type="checkbox"/> No grease lubrication

Location specification of grease holes		
Outer race	Outer diameter <input type="checkbox"/>	Mounting site <input type="checkbox"/>
Inner race	Inner diameter <input type="checkbox"/>	Mounting site <input type="checkbox"/>
High temperature (>50 °C)	<input type="checkbox"/>	Low temperature (<-25°C) <input type="checkbox"/>
Max temperature :	<input type="text"/> °C	Min.temperature : <input type="text"/> °C
Safety factor :	<input type="text"/>	Application factor:
Remarks:		

Offer details	
Quantity required	<input type="text"/> pcs.
Annual quantity required	<input type="text"/> pcs./year
Delivery term	<input type="text"/>

Other :

Please refill the form and send it at : info@tecmadrive.com . Thank you for interes !

Follow us on LinkedIn

and

visit our website



Tecma Drive S.L.
Carrer Garbí, 31
08791 Sant Llorenç d'Hortons
(Barcelona) Spain

Tel. +34 938 489 440
info@tecmadrive.com
www.tecmadrive.com